

AH2

Manually foldable display

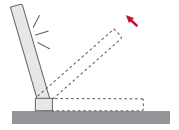

FEATURES

- Manually foldable from 0° to 110°
- Totally adjustable position
- Ready for desk mounting
- Auto-power off
- Maintenance free
- HDCP compliant
- Energy saving design
- Easy to install

GENERAL

AH2 manually foldable displays have been designed to be installed into tables or desks.

AH2 can be opened to a working position of 110° and it can be manually folded on the table surface with the screen facing down. AH2 has been designed for a very easy installation on standard furniture and it is extremely elegant and compact. The monitor is entirely built in solid milled aluminium with a natural anodised finish and has anti-reflection black edged glass which can be a multi-touch screen (optional). AH2 is available in 17.3" & 22".

TECHNICAL SPECIFICATIONS

Display

Size	FULL HD 21.5" TFT Active Matrix, widescreen
Resolution	1920 (h) x 1080 (v)
Brightness	350cd/m2
Contrast ratio	1000:1
Pixel	0.24975 (h) x 0.24975 (v) mm
Viewing angle	89°/89° (v) / 89°/89°(h)
Viewing area	476.064 (h) x 267.786 (v) mm
LED backlight lifespan	50.000 hrs
Response time	Tr 12ms, Tf 10ms
Temperature (operating/storage)	Operating 0°C – +40°C Storage -20°C – +60°C

Materials

Cabinet	Milled aluminium with anodised finishing. Monitor to be installed on table. Flush antiglare protection glass with elegant black marking
---------	---

Connectivity

Input signal	HDMI *(1 input) – HDCP Compliant
--------------	----------------------------------

Electrical

Low voltage (external power supply)	100-240Vac, 47/63Hz, 12Vdc
Power consumption	65W

Mechanical

Monitor Dimensions:	
Screen	539 x 379 x 35.50mm [21.22"x14.92"x1.40"]
Weight	15 kg / 33 lbs
Shipping Dimensions:	
Weight	16 Kg / 35.2 lbs
Shipping Box	587 x 491 x 185 mm

*Use high quality cable maximum 2 metres length

OPTIONS

- Touch screen

CERTIFICATIONS

- CE

WARRANTY

- 2 years general warranty

ARCHITECT'S SPECIFICATIONS

Professional manually foldable 21.5" monitor. Solid block of aluminium monitor housing in natural anodized finishing, with rounded corners design. Front anti-reflective black-edged glass. Fixed under-desk mounting and connection. Screen facing down when folded. No visible cables, screws or ventilation holes. HDCP compliant input, HDMI connector. External power supply.

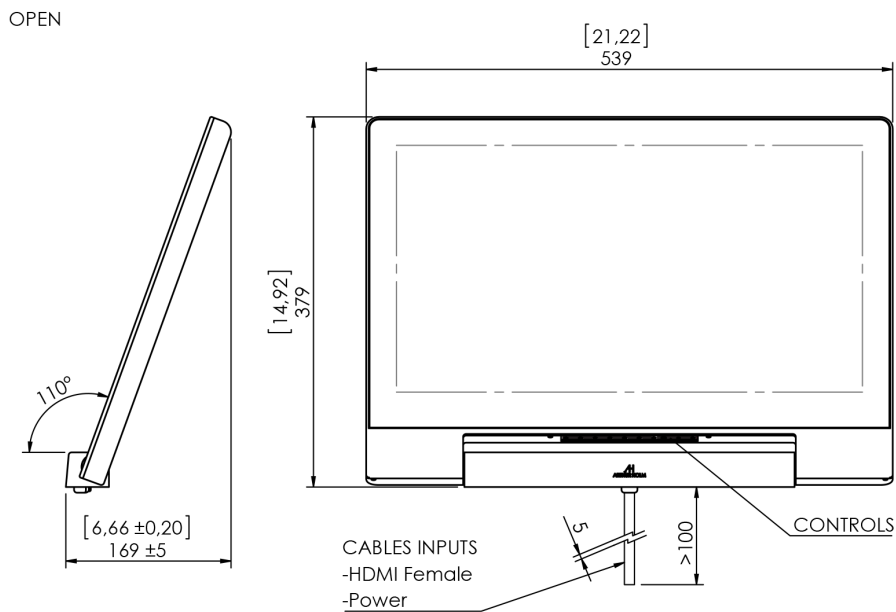

CLOSED

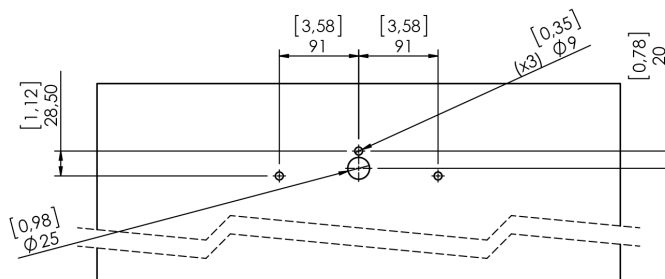
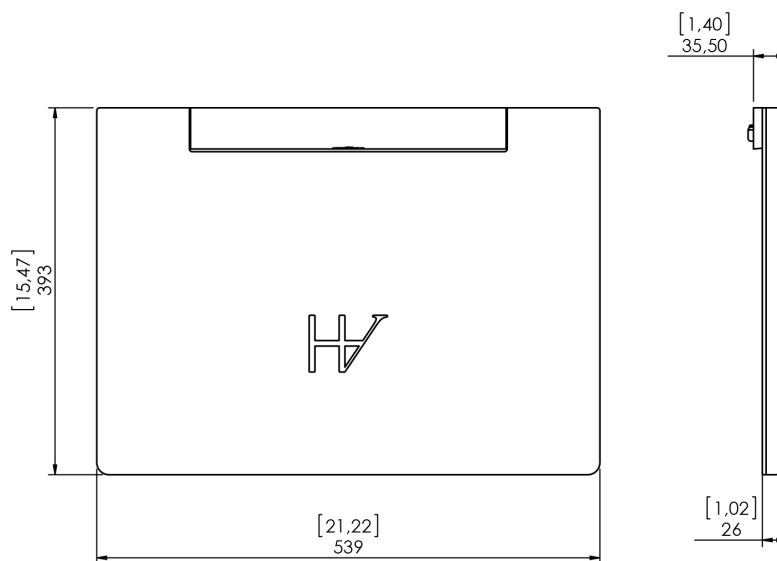

ARTHUR HOLM

Albiral Display Solutions SL · Fàtima, 25 Sant Hipòlit de Voltregà 08512 Bcelona, Spain · +34 938 502 376 · marketing@arthurholm.com
www.arthurholm.com

Arthur Holm is a registered brand of Albiral Display Solutions SL. Specifications subject to change without previous notice.