

DynamicTabLift

Retractable motorised mount for iPad® Tablets

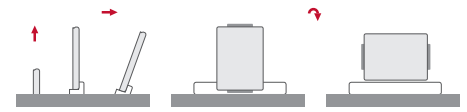

FEATURES

- Motorised lift system for iPad® tablets
- Automatic 20° inclination
- Adaptable to other tablets
- Revolving system for horizontal and vertical position
- Passive cover plate
- Interactive Setup Display
- Maintenance free
- Serial control & Remote diagnose

GENERAL

DynamicTabLift is a motorised lift system for Apple® iPad®. You can easily turn your iPad® into a screen that can be hidden when not in use to ensure a clear working environment. The lift system comes with both vertical and horizontal motorised adjusting in order to create the perfect viewing angle by tilting the monitor to a maximum of 20 degrees. An advanced fixing mechanism ensures a steady position of the iPad® even when the touch-screen is in use.

The upper cover plate is made of brushed stainless steel to ensure durability and nice design at the same time. Different colours and an embedded power supply are possible as well. This lift system can be controlled locally using the two buttons located on the cover plate, remotely through external GPI controls (contact closure) or AHnet Protocol (RS422).

TECHNICAL SPECIFICATIONS

Up/Down	GPI contact closer
	RS422 AHnet protocol (CAT 5)
Electrical	
Low voltage <i>(external power supply)</i>	100-240Vac, 50/60Hz, 12Vdc
Power consumption	25W
Shipping Dimensions:	
Weight	17 Kg / 37.4 lbs
Shipping Box	612 x 177 x 727 mm

OPTIONS

- USB cable to power the tablet
- Lock System
- Matte cover plate
- Built in DynamicTalk
- USB integrated on cover plate
- 2 USB integrated on cover plate
- USB power integrated on cover plate
- Customised cover plate with speaker, voting system, USB connector
- Prepared for underneath installation, cover plate prepared to be veneered

CERTIFICATIONS

- CE

WARRANTY

- 5 years limited warranty
- 2 years general warranty

CONNECTIVITY PANEL

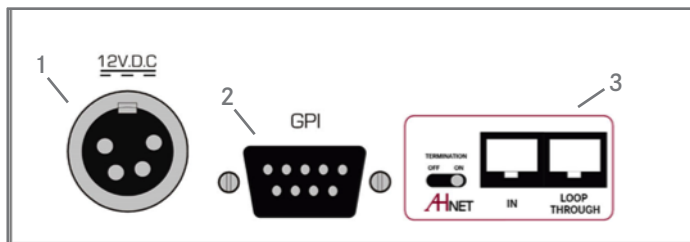

CONNECTIVITY

- 1- Power input
- 2- GPI control
- 3- AHnet control interface

INTERACTIVE SETUP DISPLAY

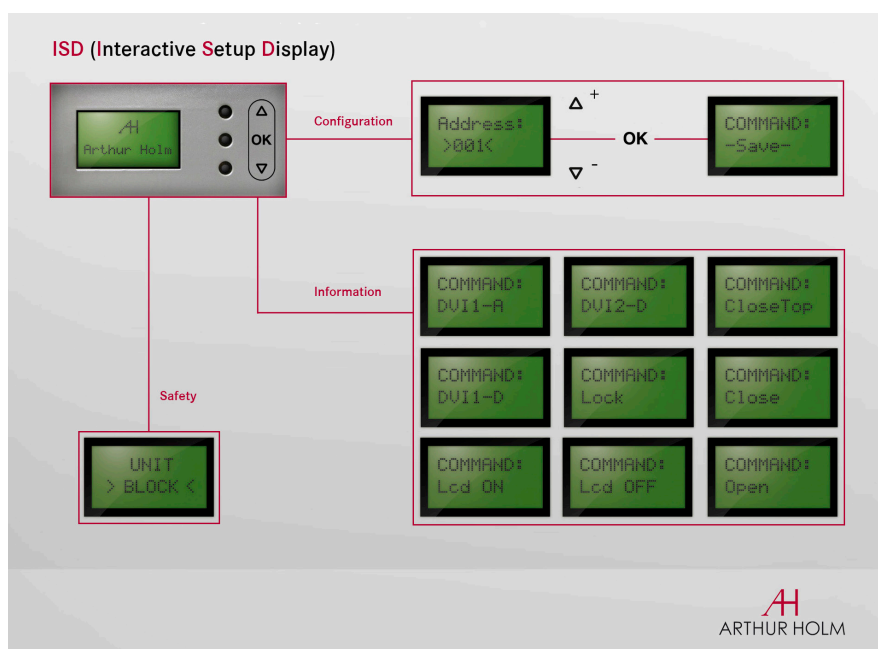

ISD

- 1- Configuration
- 2- Information
- 3- Safety

ARCHITECT'S SPECIFICATIONS

Low voltage professional motorized lift system for Apple iPad®. Cable management system for charging. Locking system for security. Portrait or landscape usage.

Compatible with AHnet open protocol over RS-422, allowing independent remote control of up to 30 units over a daisy-chain CAT-5 or CAT-6 line. Additional control by means of the buttons integrated on the cover plate that can be activated or deactivated by using the AHnet. Easy to read Interactive Set-Up Display (ISD) 1,6" LCD display for address setup and status monitoring. Safety system that

detects obstructions, stopping the unit. External power supply with 4-Pin XLR4 connector. Bottom connectivity for easy access and removal of monitor without disconnecting the monitor. Monitor housing total depth is 589 mm, plus additional spacing for connectors. Adjustable mechanical parameters through AHnet or ISD for calibration and adjustment of mechanics. Diagnostic readout on ISD for increase service and support.

GENERAL DIMENSIONS

LANDSCAPE

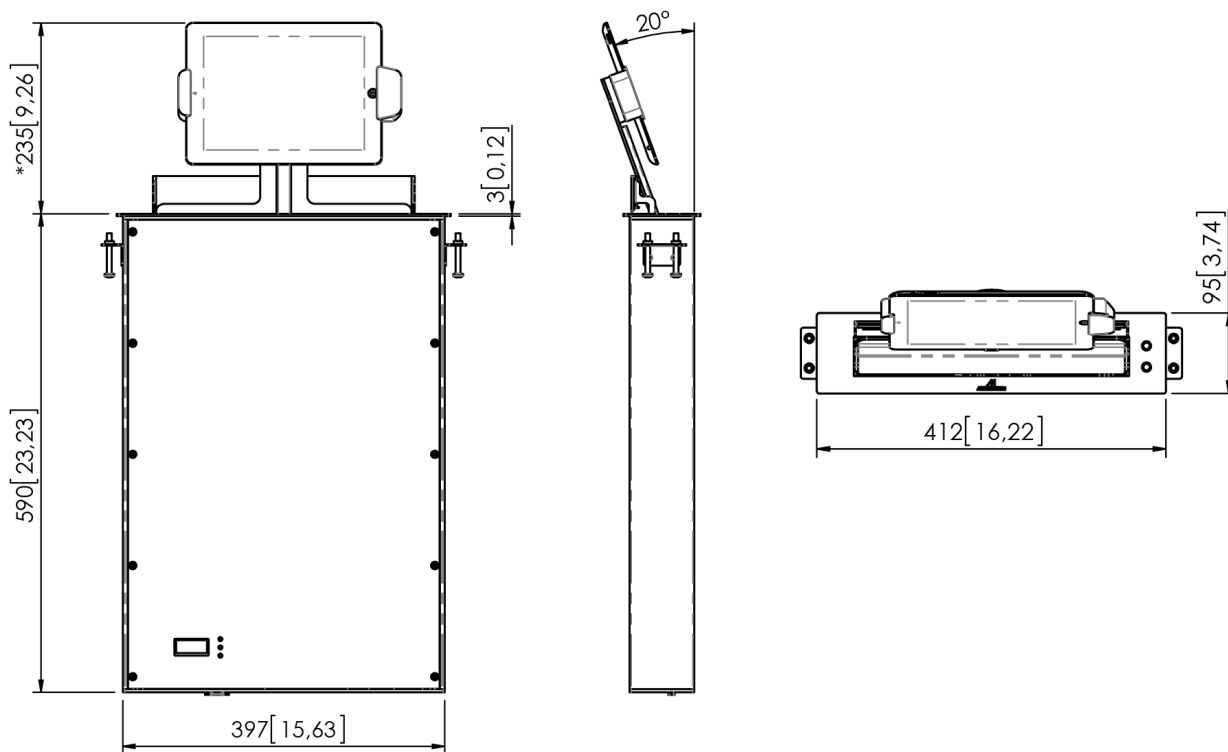

PORTRAIT
90 ° of Manually
Rotation

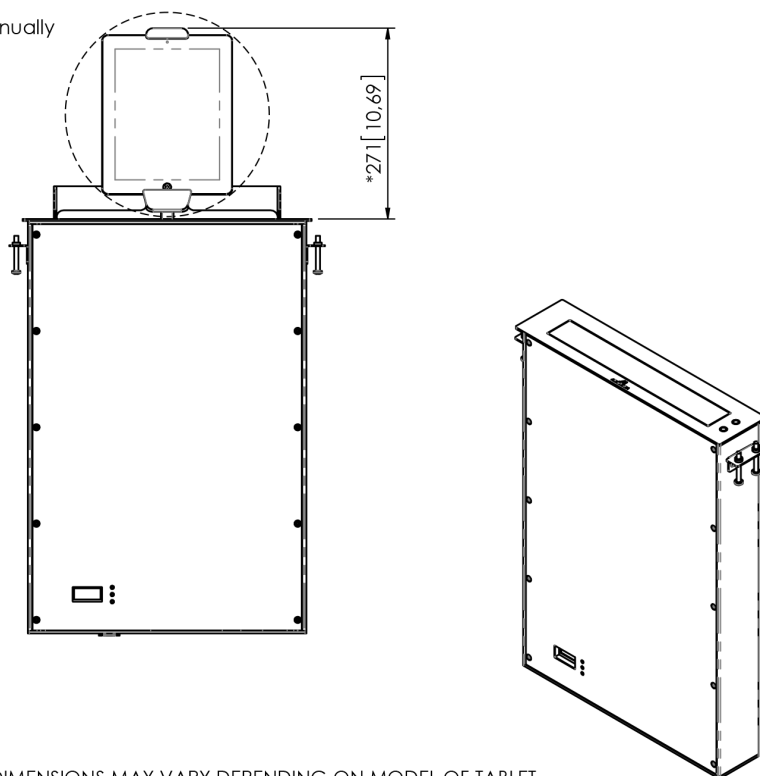

* DIMENSIONS MAY VARY DEPENDING ON MODEL OF TABLET

ARTHUR HOLM

Albiral Display Solutions SL · Fàtima, 25 Sant Hipòlit de Voltregà 08512 Bcelona, Spain · +34 938 502 376 · marketing@arthurholm.com
www.arthurholm.com

Arthur Holm is a registered brand of Albiral Display Solutions SL. Specifications subject to change without previous notice.