

# DynamicTalk UnderCover

Motorised lift system for gooseneck microphones with automated cover for veneering

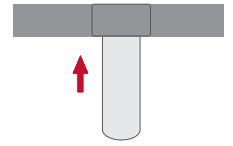

## FEATURES

- Motorised cover plate for veneering
- Universal lift system for gooseneck XLR 3 pin microphones
- LED lighting ring to indicate microphone status
- Serial control and remote diagnosis
- Individual addressing
- Auto Mechanical Movement Calibration (AH-AMMC)
- PA and Conference working modes

## GENERAL

DynamicTalk UnderCover is an elegant retractable system for gooseneck microphones with exclusive features. It allows an easy veneering to provide a seamless furniture integration. It not only makes the microphone disappear within the desk surface but it also provides a pleasant light to indicate its status. Thanks to its protective and patented lighting ring, the microphone can be safely stored and protected making meeting and conference spaces more flexible and versatile.

DynamicTalk UnderCover provides two different working modes: PA and Conference. When in PA mode, a push button placed on the stainless steel cover plate allows to activate or deactivate the microphone and the LED ring will indicate the status by changing colour from red to green.

The system will automatically silence the microphone when retracting. When in Conference mode, the microphone will be always active and both, the light ring and the access to the push button on the cover plate, will be available via GPI and GPO for remote control.

DynamicTalk UnderCover is available in 3 sizes: for 400 mm, 500 mm and 600 mm microphones. The exact length of the microphone can be adjusted via AHnet and AHlink. The AHlink is an excellent tool to diagnose, verify and configure DynamicTalk.

TECHNICAL SPECIFICATIONS

DynamicTalk Control

Up/Down Control	
Microphone control	Button on plate
	GPI contact closer
	RS-422 (RJ45 CAT 5)
Microphone Control	Button on plate
Free button	GPO general purpose
GPI/O	LEDs, up/down and switch
<b>Electrical</b>	
External power supply	100-240Vac, 47/63Hz, 12Vdc
Consumption	10W

Mechanical

Dimensions	443 x 258 x 699 mm [17.44" x10.15" x 27.51"]
Weight	7.5 kg / 16.53 lb
Shipping Dimensions:	
Weight	8 kg/ 17.63 lb
Shipping Box	730 x 220 x 185 mm [28.7" x8.6" x7.2"]

Other

AHlink	App tool to diagnose, verify and configure
AH-AMMC	Auto Mechanical Movement Calibration

CONNECTIVITY PANNEL



OPTIONS

- 5 pin XLR connector
- USB power
- Customisation with third party conference systems

WARRANTY

- 2 years general warranty

CONSULTANT, ARCHITECT AND ENGINEER SPECIFICATIONS

Professional retractable system with a maximum length of 600 mm for 3 pin XLR gooseneck microphones especially designed to be vennered. The automated cover plate shall be made of coated painted steel and shall be activated by an electric engine that drives it inside the desk. It shall provide 3 operation buttons; open/close, mute/unmute and a free GPO button. The system includes a translucent plastic rounded ring to centre and to protect the microphone. This ring shall provide a programmable green and red LED, 360° visible, to indicate the microphone status. The system shall be equipped with RS-422, RJ-45 and AHnet open protocol allowing individual remote control, setup and diagnostic of up to 30 units per line.

GPI (contact close to control movements), GPO (contact close to detect button activation) and a USB for firmware updates. The unit shall provide a safety system that detects obstructions and causes the unit to stop with an audio indication. The unit shall provide and auto calibration mode to reset mechanical speeds and safety adjustments. The system shall provide an automatic RS-422 addressing system when used in combination with ERT-30 and ERT-60. The unit shall be compatible with a wireless app that allows the exact adjustment of the microphone length, facilitates the unit's serial number, allows the activation and de-activation of the RS-422 termination and allows to change the working mode from PA to Conference.

ARTHUR HOLM

Albiral Display Solutions SL · Fàtima, 25 Sant Hipòlit de Voltregà 08512 Barcelona, Spain · +34 938 502 376 · marketing@arthurholm.com · www.arthurholm.com  
Arthur Holm is a registered brand of Albiral Display Solutions SL. Specifications subject to change without previous notice.

Technology serving Design  
Danish craftsmanship, Mediterranean soul

GENERAL DIMENSIONS

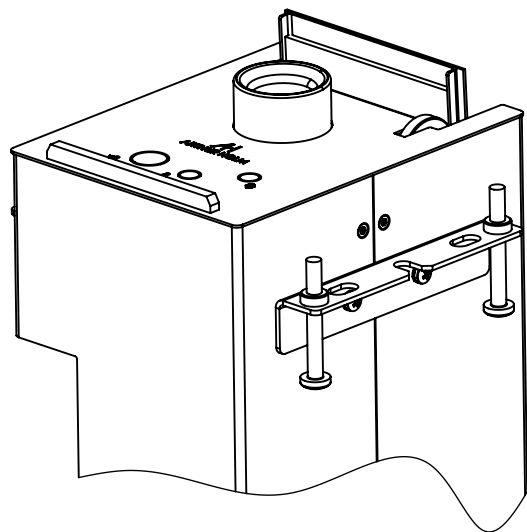
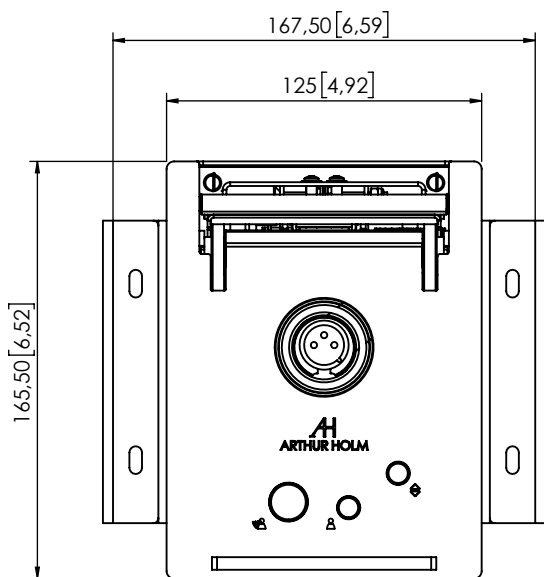
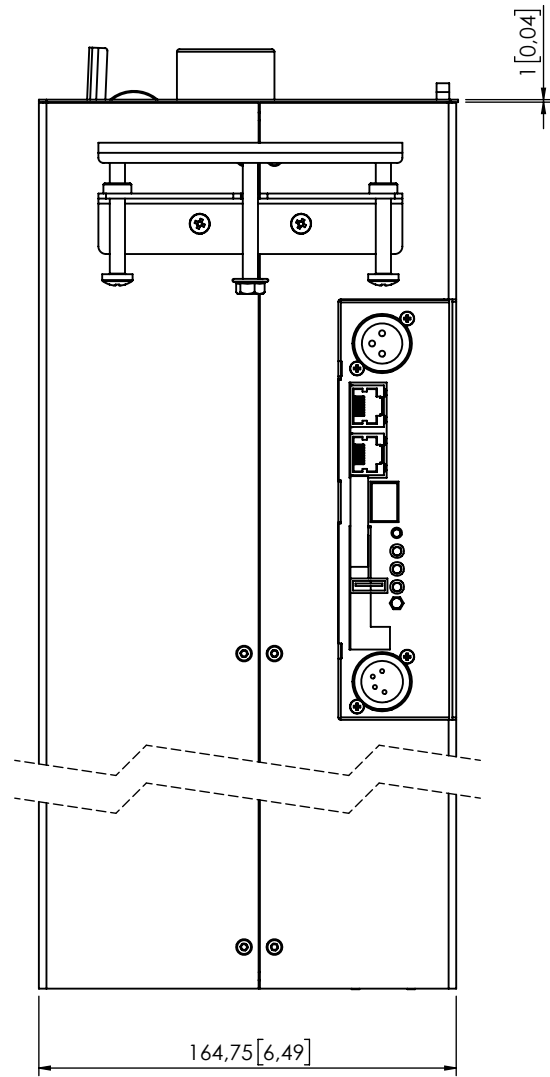
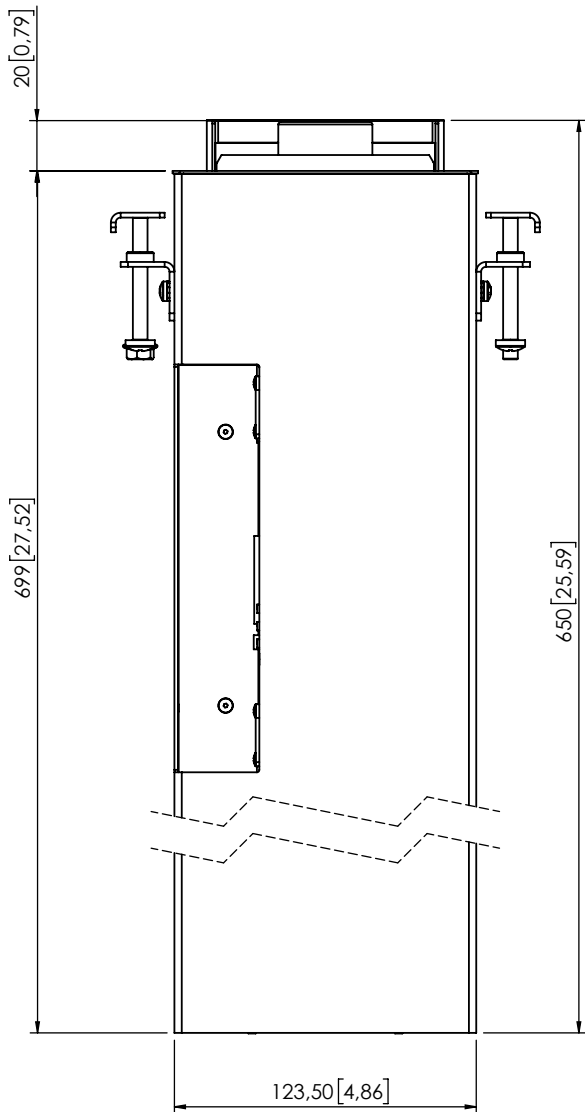

ARTHUR HOLM

Albiral Display Solutions SL · Fàtima, 25 Sant Hipòlit de Voltregà 08512 Barcelona, Spain · +34 938 502 376 · marketing@arthurholm.com · www.arthurholm.com  
 Arthur Holm is a registered brand of Albiral Display Solutions SL. Specifications subject to change without previous notice.

Technology serving Design  
 Danish craftsmanship, Mediterranean soul