

## DynamicTalk

Universal motorised lift system for gooseneck microphones

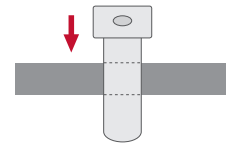

### FEATURES

- Universal lift system for gooseneck XLR 3 pin microphones
- Stainless steel cover plate with 3 buttons
- LED lighting ring to indicate microphone status 360°
- Serial control and remote diagnosis
- Individual addressing
- Auto Mechanical Movement Calibration (AH-AMMC)
- PA and Conference working modes

### GENERAL

DynamicTalk is an elegant retractable system for gooseneck microphones with exclusive features. It not only makes the microphone disappear within the desk surface but it also provides a pleasant light to indicate its status. Thanks to its protective and patented lighting ring, the microphones can be safely stored and protected making meeting and conference spaces more flexible and versatile.

DynamicTalk provides two different working modes: PA and Conference. When in PA mode, a push button placed on the stainless steel cover plate allows to activate or deactivate the microphone and the LED ring will indicate the status by changing colour from red to green.

The system will automatically silence the microphone when retracting. When in Conference mode, the microphone will be always active and both, the light ring and the access to the push button on the cover plate, will be available via GPI and GPO for remote control.

DynamicTalk is available in 3 sizes: for 400 mm, 500 mm and 600 mm microphones. The exact length of the microphone can be adjusted via AHnet and AHlink. The AHlink is an excellent tool to diagnose, verify and configure DynamicTalk.

TECHNICAL SPECIFICATIONS

DynamicTalk Control

Up/Down Control	Button on upper cover plate
	GPI contact closer
	RS-422 (RJ45 CAT 5)
Microphone Control	Button on upper cover plate
(PA Mode)	GPI contact closer RS422 (RJ45 CAT 6)
Free button	Button on upper cover plate
GPI/O	LEDs, up/down and switch
<b>Electrical</b>	
External power supply	100-240Vac, 50/60Hz, 12Vdc
Consumption	10W

Mechanical

Dimensions	110 x 110 x 604 mm [4.33"x 4.33" x 23.78"]
Weight	3.6 kg / 7.9 lb
Shipping Dimensions:	
Weight	4.6 kg/ 10.1 lb
Shipping Box	220 x 215 x 750 mm [8.6" x 8.46"x 29.52"]
Maximum microphone length	500 mm [19.6"]
<b>Other</b>	
AHlink	App tool to diagnose, verify and configure
AH-AMMC	Auto Mechanical Movement Calibration

CONNECTIVITY PANNEL

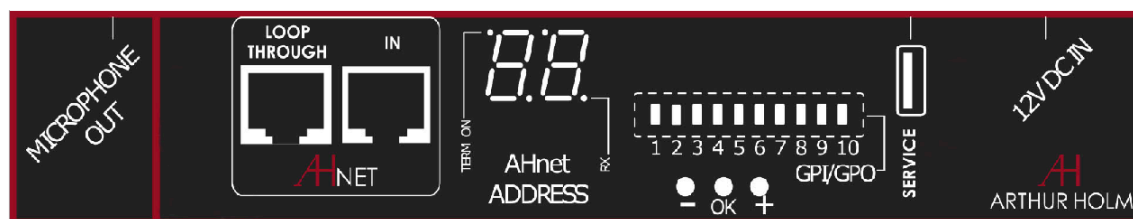

OPTIONS

- 5 pin XLR connector
- USB power integrated on cover plate
- Laser engraved logo
- Painted in different colours
- Customisation with third party conference systems

WARRANTY

- 2 years general warranty

CONSULTANT, ARCHITECT AND ENGINEER SPECIFICATIONS

Professional retractable system with a maximum length of 500 mm, for 3 pin XLR gooseneck microphones. The cover plate shall be made of brushed stainless steel and shall provide a rounded microphone coverlid and 3 operation buttons to open/close, mute/unmute the microphone and free GPO button. The lift system includes a translucent plastic rounded ring to centre the microphone during its rise and retract movement from a position hidden below the cover to a top position projected through the cover, avoiding the microphone from touching the cover plate, damaging or blocking when retracting. This ring shall provide a programmable green and red LED, 360 ° visible, to indicate the microphone status. The system shall be equipped with RS-422, RJ-45 and AHnet open protocol allowing individual remote control, setup and diagnostic of up to 30 units per line.

GPI (contact close to control movements), GPO (contact close to detect button activation) and a USB for firmware updates. The unit shall provide a safety system that detects obstructions and causes the unit to stop with an audio indication. The unit shall provide and auto calibration mode to reset mechanical speeds and safety adjustments. The system shall provide an automatic RS-422 addressing system when used in combination with ERT-30 and ERT-60.

The unit shall be compatible with a wireless app that allows the system to be adjusted with the exact microphone length, facilitates the unit's serial number, allows the activation and deactivation of the RS-422 termination and allows to change the working mode from PA to Conference.

ARTHUR HOLM

Albiral Display Solutions SL · Fàtima, 25 Sant Hipòlit de Voltregà 08512 Barcelona, Spain · +34 938 502 376 · marketing@arthurholm.com · www.arthurholm.com  
Arthur Holm is a registered brand of Albiral Display Solutions SL. Specifications subject to change without previous notice.

Technology serving Design  
Danish craftsmanship, Mediterranean soul

GENERAL DIMENSIONS

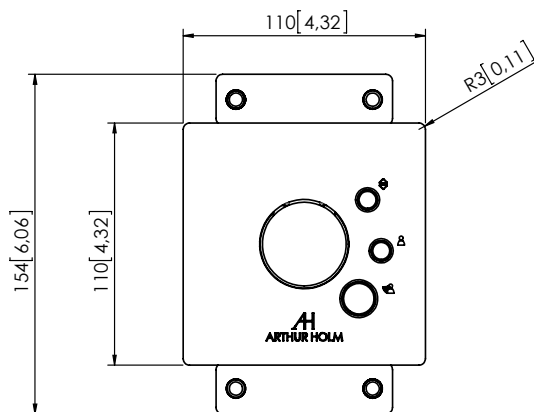
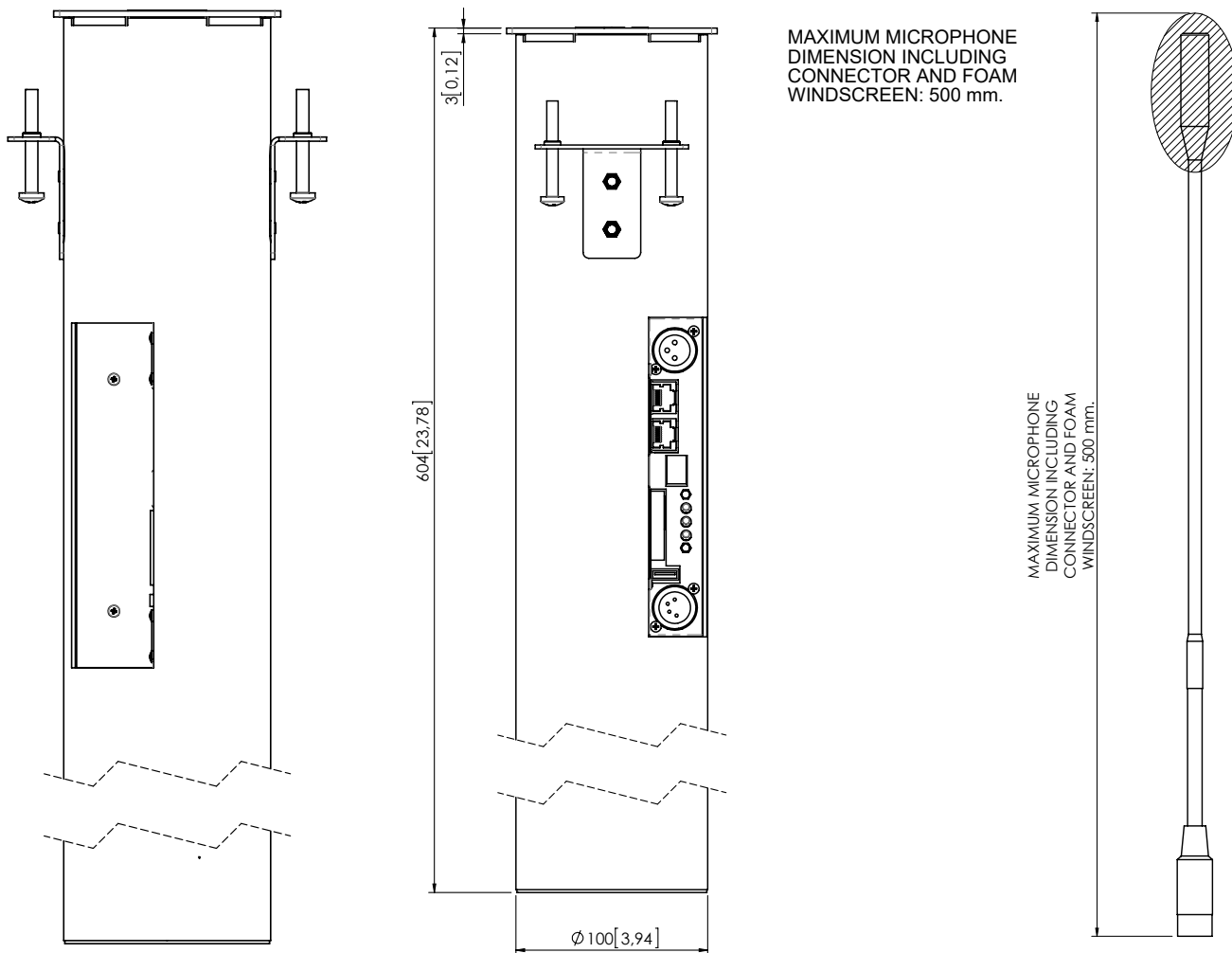

ARTHUR HOLM

Albiral Display Solutions SL · Fàtima, 25 Sant Hipòlit de Voltregà 08512 Barcelona, Spain · +34 938 502 376 · marketing@arthurholm.com · www.arthurholm.com  
 Arthur Holm is a registered brand of Albiral Display Solutions SL. Specifications subject to change without previous notice.

Technology serving Design  
 Danish craftsmanship, Mediterranean soul