

DynamicTalk UnderCover

Universal motorised lift system for gooseneck microphones with automated cover for veneering

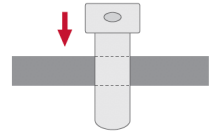

FEATURES

- Patented automated cover plate for veneering
- Universal lift system for gooseneck XLR 3 pin microphones
- Patented 360 ° LED lighting ring to indicate microphone status and protect the movement of the microphone
- PA and Conference working modes
- Auto Mechanical Movement Calibration (AH-AMMC)
- Wireless connectivity for setup and control

GENERAL

DynamicTalk UnderCover is an elegant retractable system for gooseneck microphones with exclusive features. It allows an easy veneering to provide a seamless integration in the furniture. It not only makes the microphone disappear within the desk surface but it also provides a pleasant light to indicate its status clearly indicating to the rest of the participants whose microphone is open. Thanks to its protective and patented lighting ring, the microphones can be safely stored and protected making meeting and conference spaces more flexible and versatile.

DynamicTalk provides two different working modes: PA and Conference. When in PA mode, a push button placed on the stainless steel cover plate allows to activate or de-activate the microphone and the LED ring will indicate the status by changing colour from red to green or vice versa. This microphone lifting system automatically silences the microphone when retracting whereas in conference mode the microphone remains active and can be controlled via GPI and GPO.

DynamicTalk UnderCover is available in 3 standard sizes: 400 mm, 500 mm, 600 mm (for short, medium and large microphones with XLR, 3 pin connector) and then it can be adjusted to fit the exact length of each microphone via AHnet and AHlink. Customised versions are also available for several types and sizes of conference microphones and conference brands.

ARTHUR HOLM

Albiral Display Solutions SL · Fàtima, 25 Sant Hipòlit de Voltregà 08512 Barcelona, Spain · +34 938 502 376 · marketing@arthurholm.com · www.arthurholm.com
Arthur Holm is a registered brand of Albiral Display Solutions SL. Specifications subject to change without previous notice.

Technology serving Design

DynamicTalk Control

Up/Down Control	Button on upper cover plate
	GPI contact closer
	RS-422 (RJ45 CAT 5)
Microphone Control	Button on upper cover plate
PA Mode	GPI contact closer
	RS-422 (RJ45 CAT 6)
Free button	Button on upper cover plate
GPI/O	LED, up/down and switch

Electrical

External power supply	100-240 Vac, 47/63Hz, 12Vdc
Power consumption	10W

Mechanical

Dimensions:	
Monitor Dimensions	110 x 110 x 504 mm [4.33" x 4.33" x 19.84"]
Weight	7.5 Kg / 16.53 Lbs
Shipping Dimensions:	
Weight	8 Kg/ 17.63 Lbs
Shipping Box	730 x 220 x 185 mm [28.7" x8.6" x7.2"]
Maximum microphone length	500 mm [19.68"]

Other

AHlink	App tool to diagnose, verify and configure
AH-AMMC	Auto Mechanical Movement Calibration

OPTIONS

- Integrated USB passthrough on the cover plate.
- 2 Integrated USB passthrough on the cover plate
- Integrated USB power outlet on the cover plate

CERTIFICATIONS

- CE
- FCC

WARRANTY

- 2 years general warranty

CONNECTIVITY PANEL



CONSULTANTS, ARCHITECTS AND ENGINEERS SPECIFICATIONS

The motorised lift system shall lift and retract a gooseneck microphone with a maximum length of 500 mm. and a XLR connector. The automated cover plate shall be made of coated painted steel and shall be activated by an electric engine that drives it inside the desk.

The unit shall provide 3 operation buttons to open/close, mute/unmute and a free GPO. The lift shall include a translucent plastic round ring to center the microphone during its rise and retract movement from a position hidden below the cover to a top position preventing the microphone from touching the cover plate, damaging or blocking when retracting. The LED ring shall provide a programmable red or green light and shall be 360° visible. The system shall be equipped with RS-422, RJ-45 and AHnet open protocol and shall allow individual remote control, setup and diagnosis of up to 30 units per line. The unit shall provide GPI (contact close to control the movements), GPO (contact close to detect button activation) and a USB for firmware upgrades. The unit shall provide a safety system that detects obstructions and shall cause the unit to stop with an audio indication. The unit shall provide and auto calibration mode to reset mechanical speeds and safety adjustments. The unit shall provide an automatic RS-422 addressing system when used in combination with ERT-30 and ERT-60.

The unit shall be compatible with a wireless app that allows to adjust the system to the exact microphone length, to facilitate the serial number and the activation and deactivation of the RS-422 termination and to change the working mode from PA to Conference.

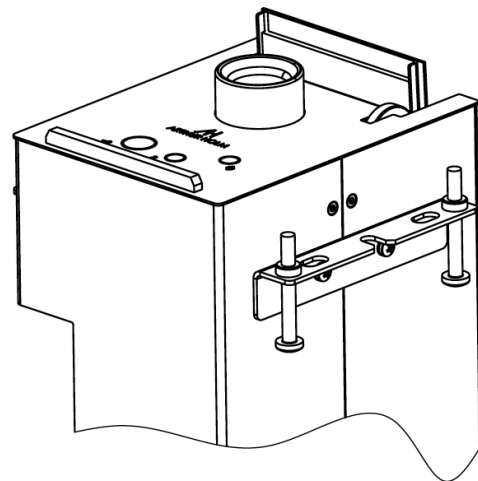
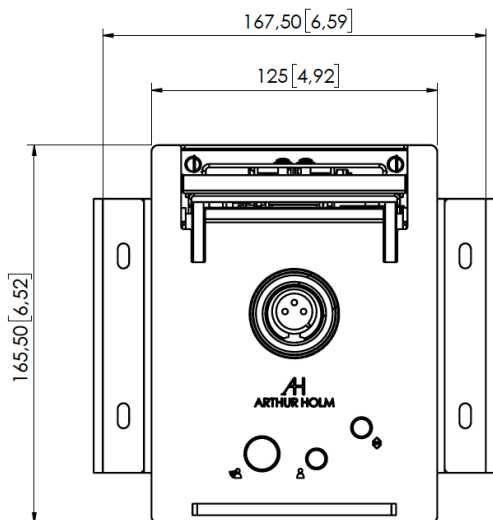
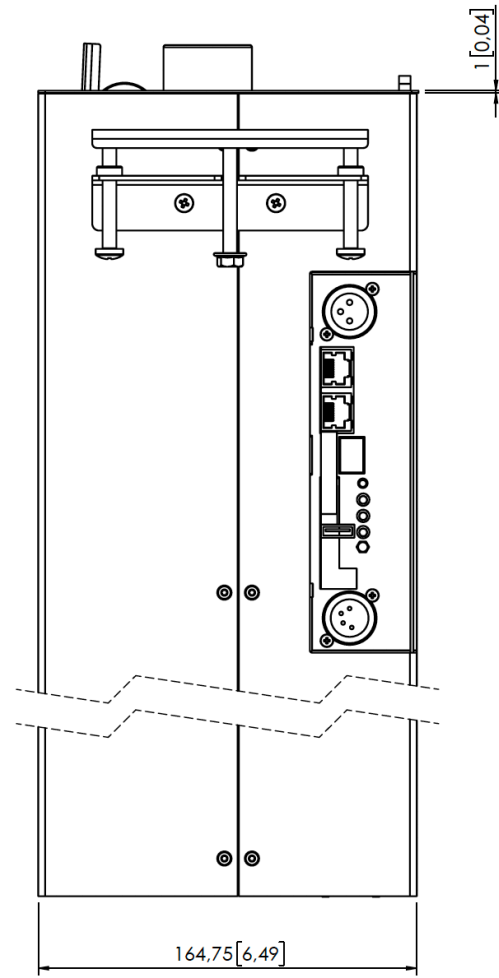
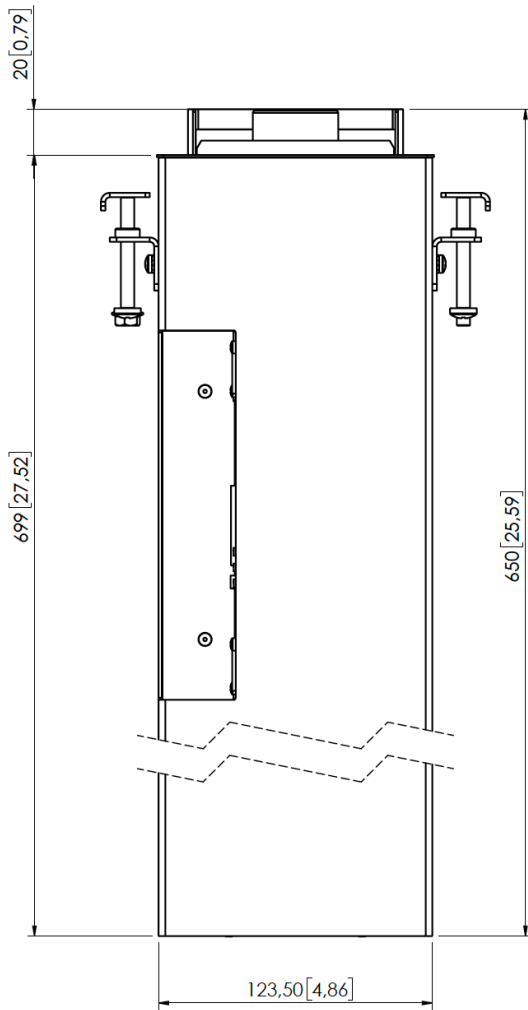

ARTHUR HOLM

Albiral Display Solutions SL · Fàtima, 25 Sant Hipòlit de Voltregà 08512 Barcelona, Spain · +34 938 502 376 · marketing@arthurholm.com · www.arthurholm.com
 Arthur Holm is a registered brand of Albiral Display Solutions SL. Specifications subject to change without previous notice.

Technology serving Design