

AH 1

HDCP compliant aluminium manually foldable monitor



FEATURES

- Milled anodised aluminium monitor
- Manually foldable from 0 to 70°
- Totally adjustable position
- No need to modify the desk surface
- USB pass-through
- Maintenance free
- Energy saving design, low consumption video controller

GENERAL

Arthur Holm AH1 are aluminium manually foldable monitors for table top with a natural anodised finish and a black cast iron base. The multifunctional iron base serves for several purposes: the unobstructed base holds firmly the aluminium monitor housing in place and provides a steepless adjustment of the viewing area. Furthermore, the base hides the cable connection and guides the cables unseen away from the monitor when using the cable exit in the centre of the base or, if needed, the rear cable outlet.

The screen position can be easily adjusted from flat on the table to 70° . The monitors include a USB passthrough from the side. AH1 are the ideal solution for auditoriums, telepresence, training rooms, meeting and conference rooms and information counters.

Display

Size	FULL HD 12.1" TFT Active Matrix, widescreen
Resolution	1280 (h) x 800 (v)
Brightness	400 cd/m2
Contrast ratio	1000:1
Pixel	0.204 (h) x 0.204 (v) mm
Viewing angle	88°/88° (u/d) / 88°/88° (l/r)
Viewing area	261.12 (h) x 163.2 (v) mm
LED backlight lifespan	50,000 hrs
Response time	Tr 15 ms, Tf 10 ms
Temperature (operating/storage)	Operating 0°C ~+40°C Storage -20°C ~+60°C

Materials

Monitor housing	Milled aluminium with anodised finishing and dark grey cast iron base
Glass	Flush antiglare protection glass with elegant black marking

Connectivity

Input signal	DVI-I (1 input) – HDCP Compliant DVI-D (1 input) – HDCP Compliant
--------------	--

Electrical

External power supply	100-240 Vac, 47/63Hz, 12Vdc
Power consumption	540W

Mechanical

Monitor Dimensions:	
Monitor Dimensions	316 x 264 x 55 mm [12.44" x 10.39" x 2.17"]
Weight	8 Kg / 17.63 Lbs
Shipping Dimensions:	
Weight	9.1 Kg / 20.06 Lbs
Shipping Box	500 x 400 x 180 mm [19.68" x 15.74" x 7.08"]

OPTIONS

- Laser engraved logo
- Black anodised
- Gold finish
- Bronze finish

CERTIFICATIONS

- CE
- FCC
- IECEE

CONNECTIVITY PANEL

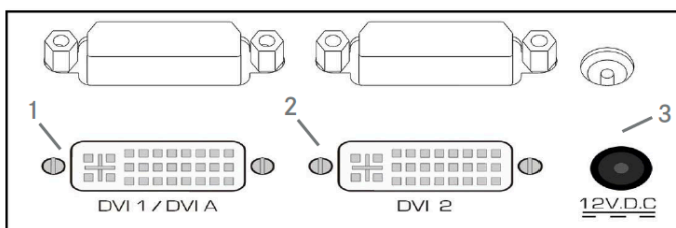

CONSULTANTS, ARCHITECTS AND ENGINEERS SPECIFICATIONS

The monitor shall provide a manually adjustable position from 0 to 70°. The monitor housing shall be made of anodised aluminium with a double sided anti-reflective 3 mm front glass with black marking. The monitor shall provide a black cast iron base with hidden cables and no visible screws.

The 12.1" Full HD monitor shall have a brightness of 400 cd/m2, a contrast ratio of 1000:1 and a backlight lifespan of 50,000 hours. The monitor shall provide 2 DVI HDCP inputs by a licensed HDCP manufacturer.

WARRANTY

- 2 years general warranty

CONNECTIVITY

- 1- DVI-1 /DVI-A video input - analog /digital
- 2- DVI-2 video input - digital
- 3- 12 D.C. power supply input

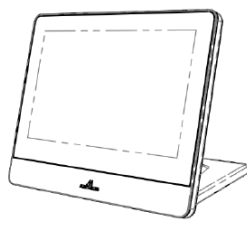
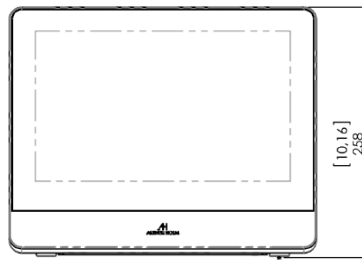
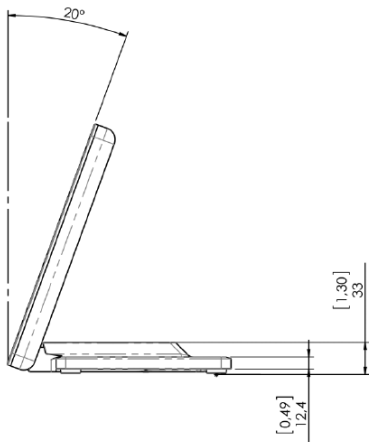

ORIENTATIVE VIEW

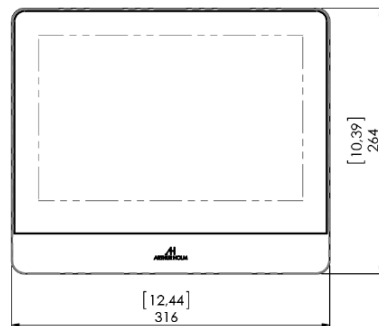
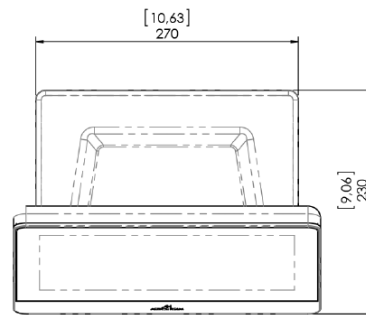

ARTHUR HOLM

Albiral Display Solutions SL · Fàtima, 25 Sant Hipòlit de Voltregà 08512 Barcelona, Spain · +34 938 502 376 · marketing@arthurholm.com · www.arthurholm.com
 Arthur Holm is a registered brand of Albiral Display Solutions SL. Specifications subject to change without previous notice.

Technology serving Design