

**DB2**

HDCP compliant retractable motorised monitor

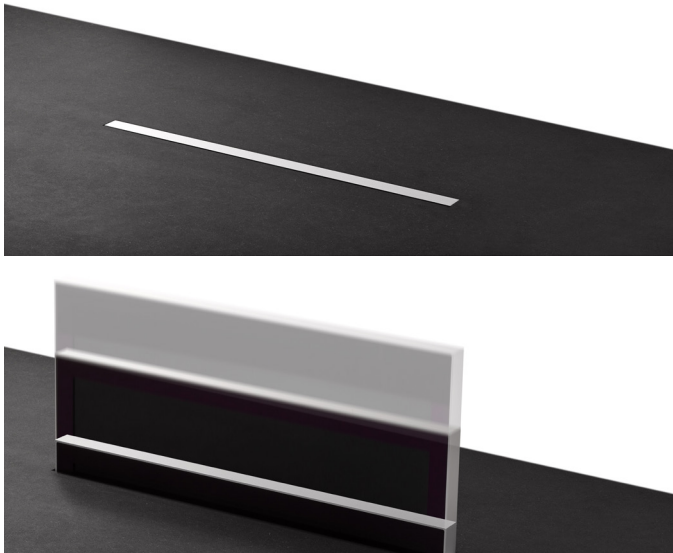
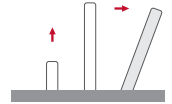

**FEATURES**

- Vertical motorised monitor with up to 20° inclination
- Adjustable screen angle tilt
- No cover plate required (monitor completely streamlined within the furniture)
- One operation sensor on top of the aluminium housing and one touch button on the glass (to rise and lower the screen and adjust the tilt angle)
- 20 mm maximum thickness
- Front double sided anti-reflective 2 sides coating 2 mm black edged glass
- Can be veneered
- Interactive Setup Display (ISD)
- Maintenance free
- HDCP compliant
- Energy saving design, low consumption video controller
- Serial control and remote diagnosis
- Wireless connectivity for setup and control
- Individual monitor addressing
- Auto Mechanical Movement Calibration (AH-AMMC)

**GENERAL**

Arthur Holm's DB2 is a motorised retractable monitor range that creates minimum impact on the furniture's design. It is easy to integrate, intuitive to use (one operation sensor located on the top of the monitor and one touch button on the glass) and almost invisible (no cover plate, neatly streamlined into furniture) when not operating. DB2 provides a harmonious silent drive with variable speeds. With a maximum thickness of 20 mm, this monitor range is elegant, beautiful from all angles and can be veneered for a seamless integration into furniture, creating a long lasting user's experience and delivering an exceptional images quality. We have selected the best possible aluminium finishing specifications in the world, providing the maximum technical and visual performance.

The screen is protected with an anti-reflective 2 side coating 2 mm black edged glass. DB2 are available from 10" to 23.8" with 2 DVI-HDCP compliant inputs and equipped with an Interactive Setup Display (ISD) allowing the control, setup and diagnose of the monitors. Monitors provide RS-422 I/O allowing the remote control of movements, speed, safety settings, brightness, contrast and backlight. The monitors are equipped with Auto Mechanical Movement Calibration (AH-AMMC). The use of the Arthur Holm's ERT will enable the address configuration of all the monitors installed by simply pressing a button. The AHlink Android and iOS App allows getting the monitor's serial number without removing the unit from the table and allows access to the setup and control menu.

**ARTHUR HOLM**

Albiral Display Solutions SL · Fàtima, 25 Sant Hipòlit de Voltregà 08512 Barcelona, Spain · +34 938 502 376 · marketing@arthurholm.com · www.arthurholm.com  
Arthur Holm is a registered brand of Albiral Display Solutions SL. Specifications subject to change without previous notice.

Technology serving Design

**Display**

Size	4K 23.8" TFT Active Matrix, widescreen format. LED backlight
Resolution	3840 (h) x 2160 (v)
Brightness	250 cd/m2
Contrast ratio	1000:1
Pixel	0.13725 (h) x 0.13725 (v) mm
Viewing angle	178°(v) 178°(h)
Viewing area	527.04 (h) x 296.46 (v) mm
LED backlight lifespan	30,000 hrs
Response time	Tg-g 14ms
Temperature (operating/storage)	Operating 0°C ~+40°C Storage -20°C ~+60°C

**Materials**

Monitor housing	Solid mechanised aluminium housing with anodised finish. Front black serigraphed glass
-----------------	--

**Connectivity**

Input signal	2 x DisplayPort 2 x HDMI - HDCP compliant
RJ45 CAT6 (with loop)	Addressable RS422 monitor control by AHnet protocol
GPI (SubD9)	Up/Down control
USB	For service

**Control**

RJ45, RS-422 (I/O), AHNet protocol
Addressing
Termination switch
GPI
IR Remote control (monitor adjustments): 1/5

**Movement's Control**

User interface on monitor	(Up/Down) Capacitive touch sensor
Remote	RS-422 I/O, GPI

**Accessories**

ERT	Ethernet Interface Unit
-----	-------------------------

**Mechanical**

Monitor Dimensions:	
Screen	559.20 x 334.50 x 20 mm [22" x 13.16" x 0.79"]
Top frame	559.20 x 20 mm [22" x 0.79"]
Housing below the table	638 x 657 x 82 mm [25.13" x 25.86" x 3.23"]
Weight	25 Kg / 55.12 Lbs
Shipping Dimensions:	
Weight	26 Kg / 57.32 Lbs
Shipping Box	735 x 175 x 745 mm [28.9" x 6.8" x 29.3"]

**OPTIONS**

- Projected capacitive multi-touch screen
- Black anodised
- Gold finish
- Bronze finish
- Painted
- Aluminium cover plate

**WARRANTY**

- 5 years limited warranty
- 2 years general warranty

**CERTIFICATIONS**

- CE
- FCC
- IECEE

## CONNECTIVITY PANEL

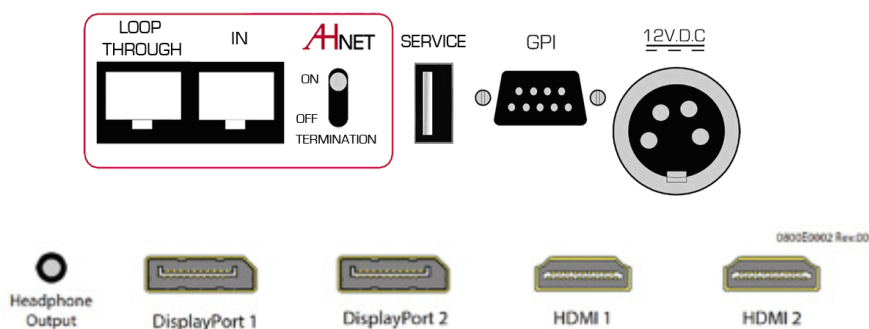

## INTERACTIVE SETUP DISPLAY (ISD)

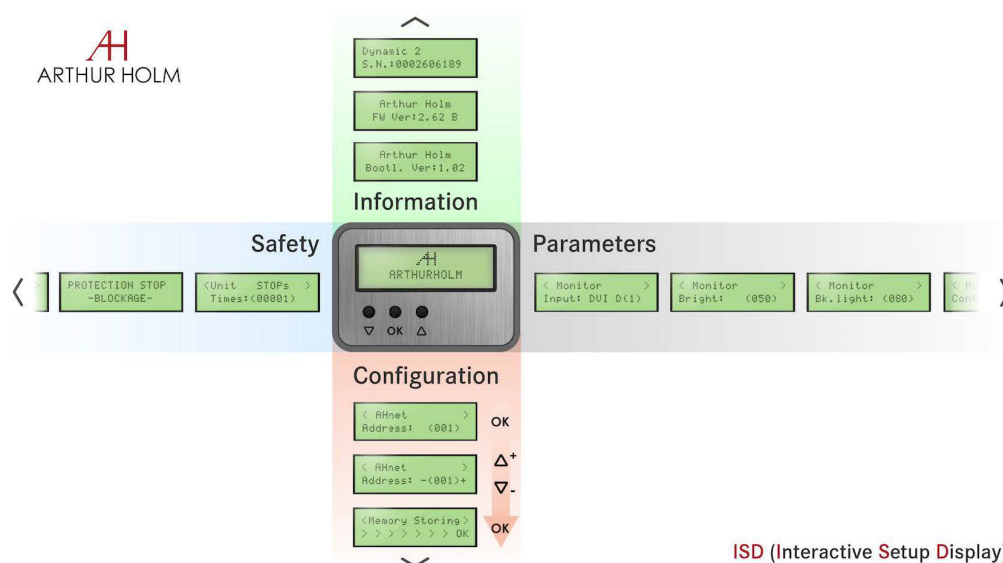

ISD (Interactive Setup Display)

## CONSULTANTS, ARCHITECTS AND ENGINEERS SPECIFICATIONS

Vertically retractable motorised 23.8" 4K resolution, professional monitor. The monitor housing shall be made of milled anodised aluminium with a maximum thickness of 20 mm and the screen shall be protected with an anti-reflecting 2 side coating black edged 2 mm glass. The monitor shall allow its installation into furniture opening with a maximum width of 24 mm and shall be designed to be veneered to match the furniture's surface.

The monitor housing shall be flush with the table when the monitor is in recessed position. A capacitive button that shall be placed at the top of the monitor shall activate the monitor's movements. The monitor shall have a brightness of 250 cd/m<sup>2</sup>, a contrast ratio of 1000:1 and a backlight lifespan of 30,000 hours.

The monitor shall provide 2 DisplayPort and 2 HDMI inputs.

The monitor shall provide an addressable RS-422 and an easy to read Interactive Setup Display (ISD) to access the safety parameters, the setup of the speed and the control of the brightness, contrast and backlight. The monitor shall be able to run an auto adjustment program to reset the factory setups.

The monitor shall provide a USB port for firmware upgrades. The monitor shall be controlled by a wireless Android and iOS App providing information about the monitor's serial number, and providing access to the control and to the setup menu.

### ARTHUR HOLM

Albiral Display Solutions SL · Fàtima, 25 Sant Hipòlit de Voltregà 08512 Barcelona, Spain · +34 938 502 376 · marketing@arthurholm.com · www.arthurholm.com  
Arthur Holm is a registered brand of Albiral Display Solutions SL. Specifications subject to change without previous notice.

Technology serving Design

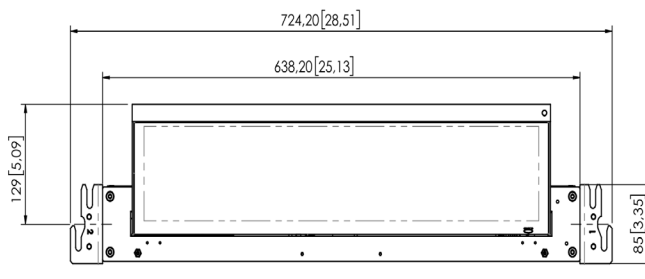
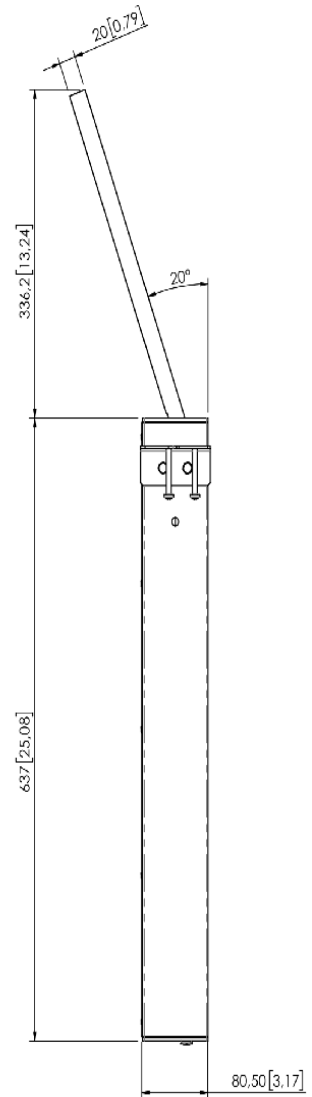
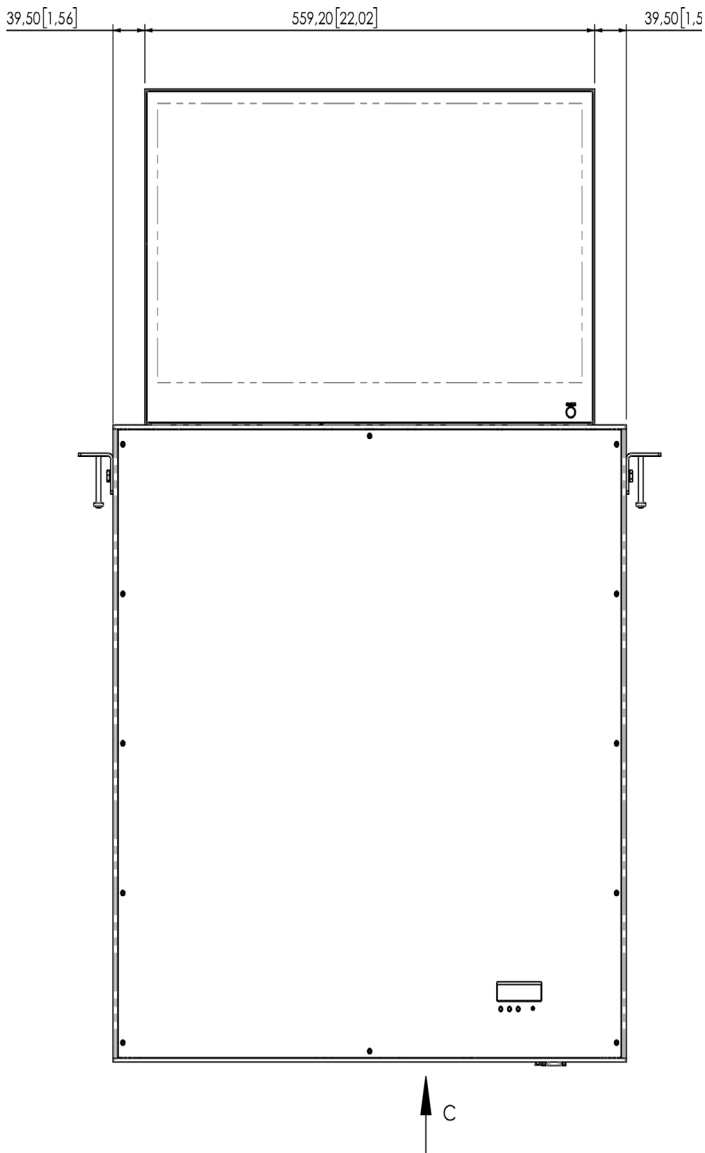

VIEW C

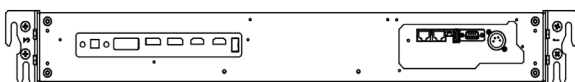

ARTHUR HOLM

Albiral Display Solutions SL · Fàtima, 25 Sant Hipòlit de Voltregà 08512 Barcelona, Spain · +34 938 502 376 · marketing@arthurholm.com · www.arthurholm.com  
 Arthur Holm is a registered brand of Albiral Display Solutions SL. Specifications subject to change without previous notice.

Technology serving Design