

## CourtesyBox

Motorised courtesy boxes for furniture integration

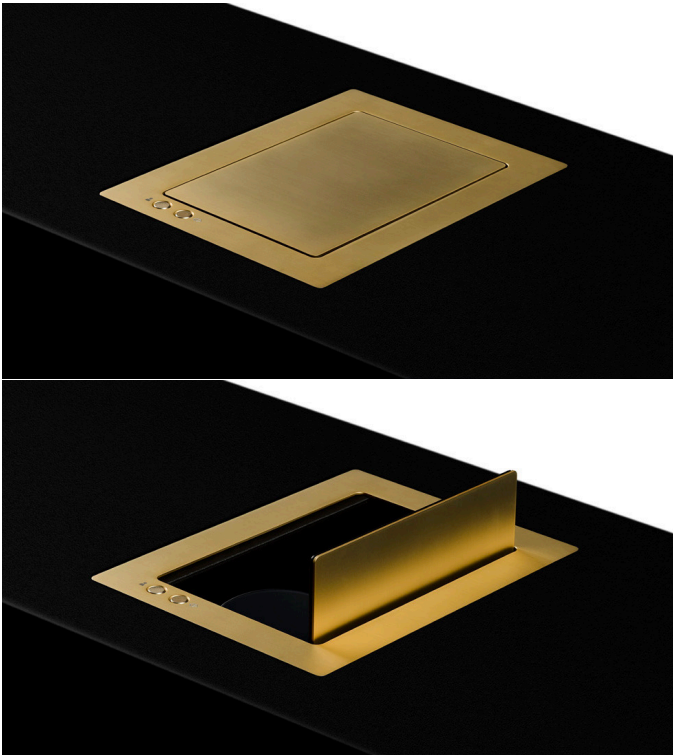

### FEATURES

- Motorised housing for furniture integration
- Prepared for veneering
- Maintenance free
- Personalised finishes
- Control buttons on cover plate
- Easy installation
- Compact, space optimising and elegant solution
- Silent, reliable and durable solution
- Serial control and remote diagnosis

### GENERAL

The CourtesyBox is an outstanding motorised solution to hide anything in the tables, keeping the surface clean. Expect the unexpected with the CourtesyBox for water and glasses or as a motorised tissue box. The CourtesyBox can be controlled locally or remotely through AHnet (RS-422) and the open/close button can be disabled or locked.

The CourtesyBox can also be daisy chained with all the rest of Arthur Holm motorised products using CAT6 cables for control. The CourtesyBox is created to be installed in horizontal surfaces of furniture. When the hatch is closed, it leaves the desk free of any obtrusive elements. The AHlink app is available for Android and iOS.

**Materials**

Housing	Brushed stainless steel
---------	-------------------------

**Connectivity**

RJ45 CAT6 (with loop)	Addressable RS-422 monitor control by AHnet protocol
-----------------------	--

**Engine**

Control Up/Down	Buttons on cover plate, AHnet (RS422), Connection (RJ45) and Wiring (CAT-6)
-----------------	---

Electronic control	PWM
--------------------	-----

Ethernet AHnet commands	
-------------------------	--

**Electrical**

External power supply	100-240 Vac, 50/60Hz, 12Vdc
-----------------------	-----------------------------

Power consumption	10W
-------------------	-----

**Mechanical**

Case Dimensions:	
------------------	--

Upper cover plate	212 x 160 mm [8.35" x 6.30"]
-------------------	---------------------------------

Cover plate	196.90 x 258 x 143.60 mm [7.75" x 10.17" x 5.65"]
-------------	--

Weight	5.3 Kg / 11.68 Lbs
--------	--------------------

Shipping Dimensions:	
----------------------	--

Weight	6.3 Kg / 13.88 Lbs
--------	--------------------

Shipping Box	300 x 250 x 365 mm [11.81" x 9.84" x 14.37"]
--------------	---

**OPTIONS**

- Painted
- Gold finish
- Bronze finish
- Black anodised

**CERTIFICATIONS**

- CE
- FCC

**WARRANTY**

- 2 years general warranty

**CONNECTIVITY PANEL**

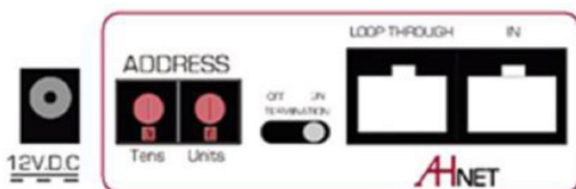

**CONSULTANTS, ARCHITECTS AND ENGINEER'S SPECIFICATIONS**

The motorised box shall be made of stainless steel. The unit shall be controlled locally or remotely through R422 and the open/close button shall be capable to be disabled or locked.

The box shall be designed to hide bottles and glasses and the hatch shall slide down within the furniture. The motorised box shall be controllable by a wireless app. A wireless app shall show the serial number of the unit, the firmware version and shall control the open/close movement.

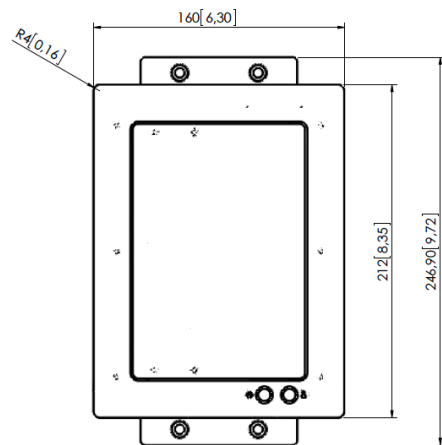
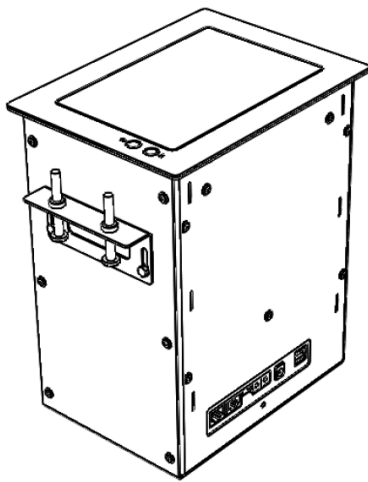
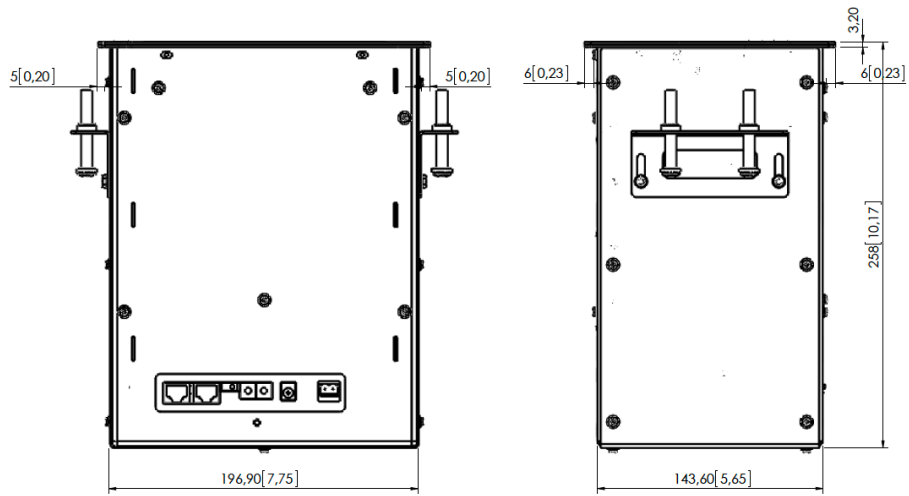

BOTTLE DIMENSIONS

GLASS DIMENSIONS

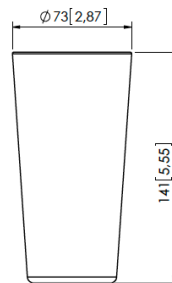
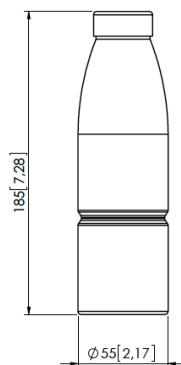

ARTHUR HOLM

Albiral Display Solutions SL · Fàtima, 25 Sant Hipòlit de Voltregà 08512 Barcelona, Spain · +34 938 502 376 · marketing@arthurholm.com · www.arthurholm.com  
 Arthur Holm is a registered brand of Albiral Display Solutions SL. Specifications subject to change without previous notice.

Technology Serving Design