

DynamicReceptionMonitor

HDCP compliant aluminium motorised monitor for desk integration



FEATURES

- Motorised adjustable height
- 140° manual rotation
- Stainless steel rotary arm
- Ergonomic
- 24/7 design
- Maintenance free
- Energy saving design, low consumption video controller

GENERAL

Arthur Holm DynamicReceptionMonitor is a motorised adjustable reception monitor for a perfect fit. It provides a quick motorised adjustment to match each individual need when working to create a correct and preferable work environment in a front desk.

The professional Arthur Holm DynamicReceptionMonitor incorporates the latest professional technologies to ensure a perfect workplace. It offers a non-obstructive design in which all technical interfaces and cables are internal, so the front desk is free of cables and obstructive components, creating a cleaner work environment.

The DynamicReceptionMonitor has been designed to be integrated in tables or desks. The base of the monitor is installed on the surface and its connectivity is placed below the table, making the installation clean and minimalistic. The elegant monitor housing is made of milled aluminium and it includes an antiglare protection glass with black marking. The stainless steel rotary arm of the monitor offers a motorised adjustable height for a perfect fit.

ARTHUR HOLM

Albiral Display Solutions SL · Fàtima, 25 Sant Hipòlit de Voltregà 08512 Barcelona, Spain · +34 938 502 376 · marketing@arthurholm.com · www.arthurholm.com
Arthur Holm is a registered brand of Albiral Display Solutions SL. Specifications subject to change without previous notice.

Technology serving Design

Display

Size	Full HD 21.5" TFT Active Matrix, widescreen
Resolution	1920 (h) x 1080 (v)
Brightness	350 cd/m2
Contrast ratio	1000:1
Pixel	0.24975 (h) x 0.24975 (v) mm
Viewing angle	89° /89° (L/R)/89° /89°(U/D)
Viewing area	476.064 (h) x 267.786 (v)
LED backlight lifespan	50,000 hrs
Response time	Tr 12ms, Tf 10 ms
Temperature (operating/storage)	Operating 0°C ~+40°C Storage -20°C ~+60°C

Materials

Monitor housing	Anodised aluminium
Glass	Anti-reflective glass
Support	Stainless steel. Adjustable viewing angle

Connectivity

Input signal	12V Power connector 1 HDMI aerial connector
--------------	--

Electrical

External power supply	100-240 Vac, 47/63Hz, 12Vdc
Power consumption screen	32W
Power consumption lift	95W (only during height adjustment)

Mechanical

Monitor Dimensions:	
Monitor dimensions	539 x 369 x 28 mm [21.22" x 14" x 1.10"]
Support dimensions	Ø50.90 x 290 mm [2.00" x 11.42"]
Housing below the table	Ø70.00 x 457 mm [2.76" x 17.99"]
Weight	27 Kg / 59.52 Lbs
Shipping Dimensions:	
Weight	28.1 Kg / 61.94 Lbs
Shipping Box	920 x 660 x 240 mm [36.22" x 26" x 9.45"]

OPTIONS

- Laser engraved logo
- Projected capacitive multi-touch screen

CERTIFICATIONS

- CE
- FCC
- IECEE CB

WARRANTY

- 2 years general warranty

CONSULTANTS, ARCHITECTS AND ENGINEERS SPECIFICATIONS

The monitor shall provide a motorised adjustable height by pushing and holding a front button and shall be manually rotatory by 70° right and 70° left. The monitor housing shall be made of anodised aluminium with a double sided anti-reflective 3 mm front glass with black marking. The monitor shall provide a stainless steel arm and under desk clamp mounting. The 21.5" Full HD monitor shall have a brightness of 350 cd/m2, a contrast ratio of 1000:1 and a backlight lifespan of 50,000 hours. The monitor shall provide an HDMI input by a licensed HDCP manufacturer.

MONITOR CONNECTIVITY

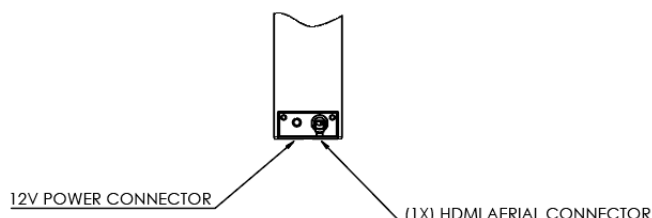

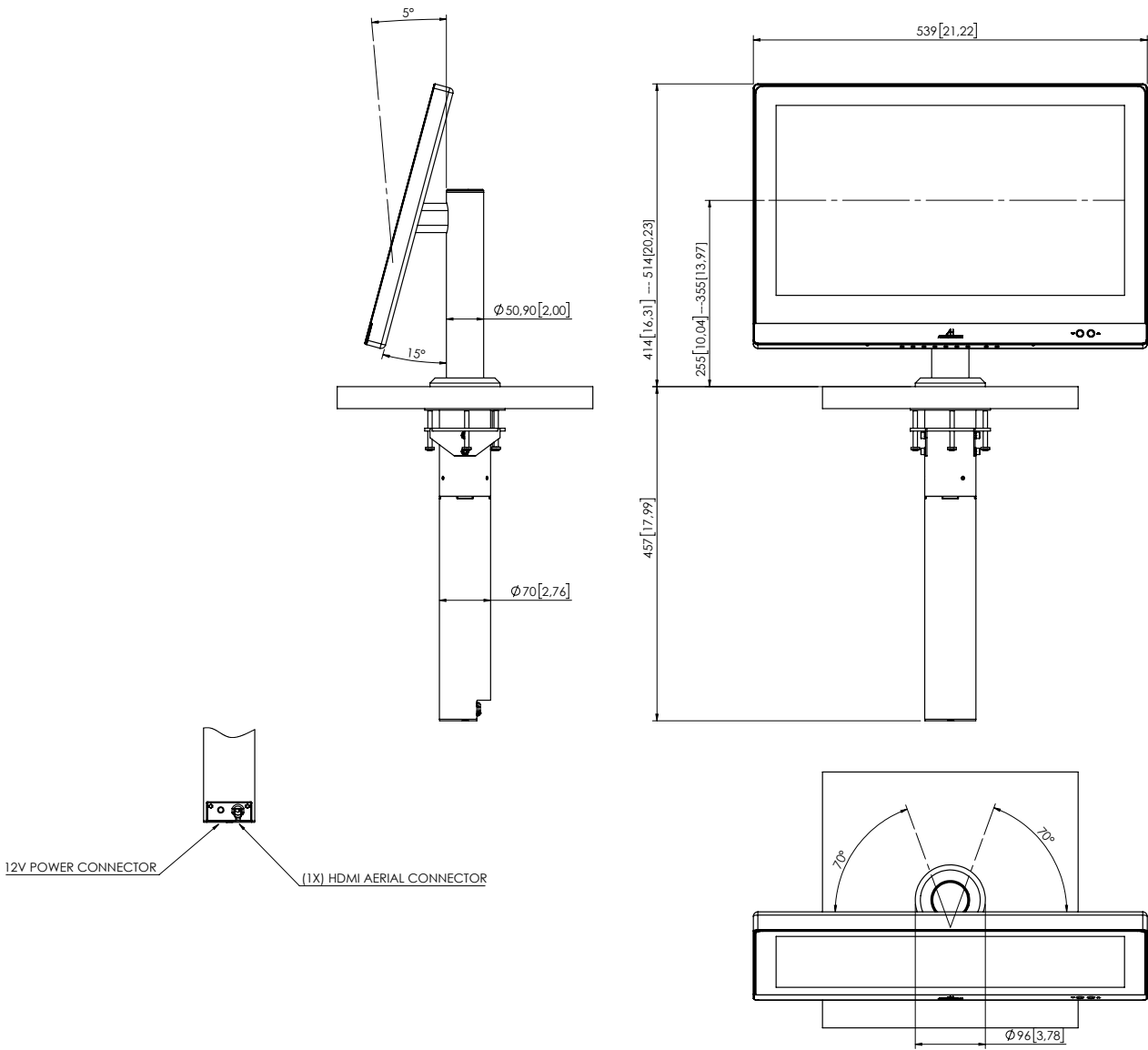

ARTHUR HOLM

Albiral Display Solutions SL · Fàtima, 25 Sant Hipòlit de Voltregà 08512 Barcelona, Spain · +34 938 502 376 · marketing@arthurholm.com · www.arthurholm.com
 Arthur Holm is a registered brand of Albiral Display Solutions SL. Specifications subject to change without previous notice.

Technology serving Design