

## AH2

HDCP compliant aluminum manually foldable monitor

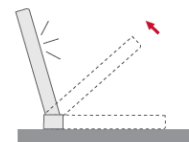

### Highlights

- Milled anodized aluminum monitor
- Manually foldable from 0 to 110°
- Totally adjustable position
- Auto-power off
- Ready for desk mounting
- Maintenance free
- Energy saving design, low consumption video controller

### General

Arthur Holm AH2 manually foldable monitors are the perfect solution to create flexible and versatile tables needing to optimise the space. The monitor is fixed to the table surface through its milled aluminum base, allowing the user to adjust the viewing area of the monitor and holding the monitor in a firm working position. All connectors are placed under the table and cables are passed unseen through the base to the monitor, leaving the monitor minimalist design unobstructed.

AH2 are aluminum monitors that can be easily folded down to leave a direct line of sight to the other participants or activities taking place in the room. Furthermore, the low profile space needed for their installation allows users to have a large cable-free surface to work using both the screen and other materials over the desk.

## Display

Size	Full HD 21.5" TFT Active Matrix, widescreen
Resolution	1920 (h) x 1080 (v)
Brightness	350 cd/m2
Contrast ratio	1000:1
Pixel	0.24975 (h) x 0.24975 (v) mm
Viewing angle	89° /89° (L/R)/89° /89°(U/D)
Viewing area	476.064 (h) x 267.786 (v)
LED backlight lifespan	50,000 hrs
Response time	Tr 12ms, Tf 10 ms
Temperature (operating/storage)	Operating 0°C ~+40°C Storage -20°C ~+60°C

## Materials

Monitor housing	Milled aluminum with anodized finishing
Glass	AR 2-side with an anti-reflective coating on the glass surface. Thickness: 3.0 ± 0.3 mm

## Connectivity

Input signal	HDMI *(1 input) – HDCP Compliant *Use high quality cable maximum 2 metres length
--------------	---

## Electrical

External power supply	100-240 Vac, 47/63Hz, 12Vdc
Power consumption	65W

## Mechanical

Monitor dimensions	539 x 393 x 35.5 mm [21.22" x 14" x 1.10"]
Weight	11 Kg / 24.25 Lbs
Shipping Dimensions:	
Weight	12.1 Kg / 26.67 Lbs
Shipping Box	635 x 530 x 225 mm [25" x 20.86" x 8.85"]

## Options

- Projected capacitive multi-touch screen

## Finishes

- Laser engraved logo
- Black anodized
- Gold finish

## Certifications

- CE
- FCC
- IECEE CB

## Consultants, architects and engineers specifications

The monitor shall provide a manually adjustable position from 0 to 110°. The monitor housing shall be made of anodized aluminum with an anti-reflective 2 sides coating 3 mm black edged glass. The monitor shall provide a milled aluminum base, allowing the user to adjust the viewing area of the monitor and holding the monitor in a firm working position. All connectors shall be placed under the table and cables shall be unseen through the base to the monitor. The 21.5" Full HD monitor shall have a brightness of 350cd/m2, a contrast ratio of 1000:1 and a backlight lifespan of 50,000 hours. The monitor shall provide 1 HDMI HDCP input by a licensed HDCP manufacturer.

## Warranty

- 2 years general warranty

OPEN

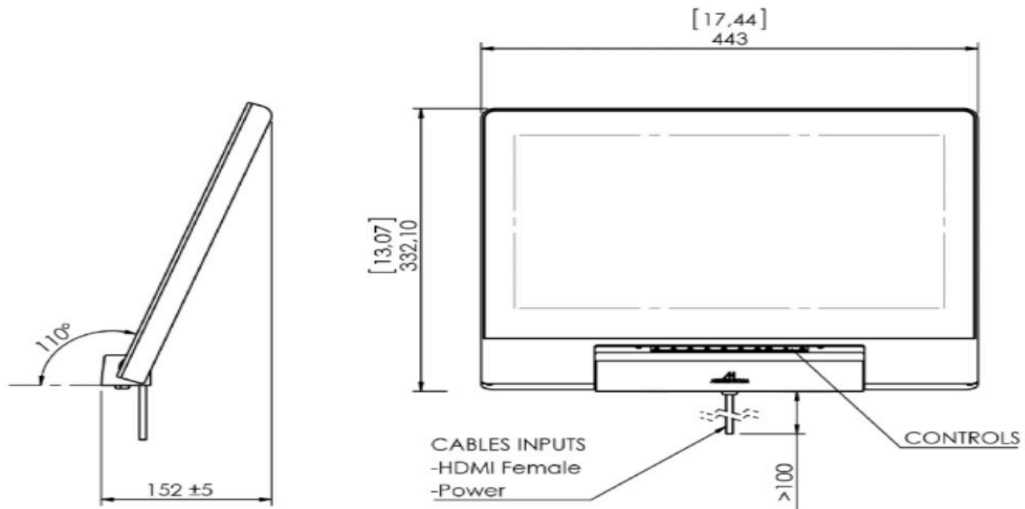

CLOSED

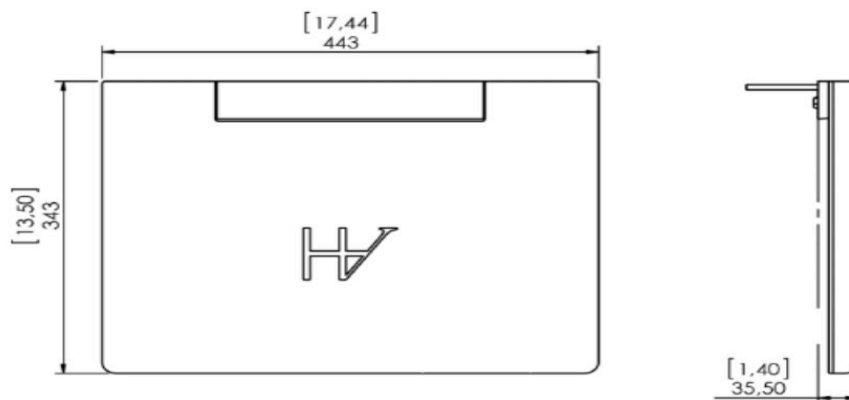

PATTERN HOLE

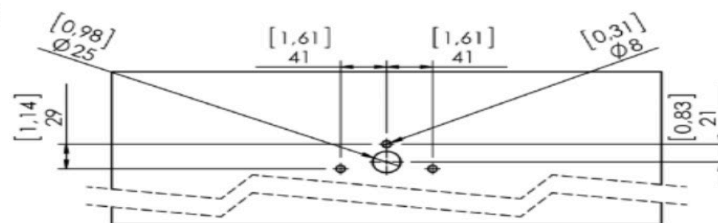

ARTHUR HOLM

Albiral Display Solutions SL · Fàtima, 25 Sant Hipòlit de Voltregà 08512 Barcelona, Spain · +34 938 502 376 · marketing@arthurholm.com · www.arthurholm.com  
 Arthur Holm is a registered brand of Albiral Display Solutions SL. Specifications subject to change without previous notice.

Technology serving Design