

DynamicTalkB

Motorized microphone lift system for boundary table top microphones

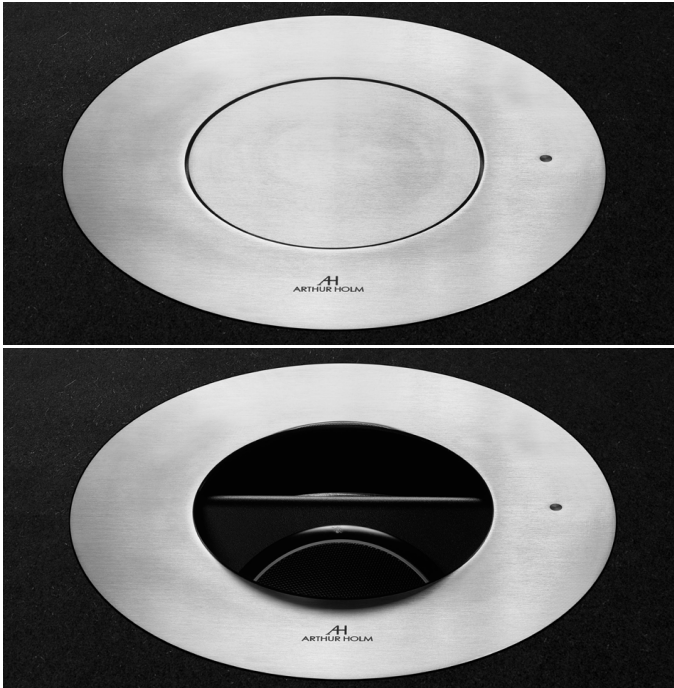

Highlights

- Motorized lift for boundary table top microphones
- Compact, space optimising and stylish solution
- Low profile enclosure
- Maintenance free
- Compatible wireless connectivity for setup and control via AHliInk

General

DynamicTalkB is a motorized microphone lift for boundary microphones and similar, controllable via AHnet protocol or directly on the device using the flush mounted touch control sensor.

The Arthur Holm DynamicTalkB microphone lift is designed to hide boundary microphones when not in use with a smooth, elegant and silent movement.

The microphone lift is capable of providing commands for automatic mute of the microphone (depending on the model and maker of the microphone) when moving and in storage position.

The housing is made out of steel and the upper cover plate is made in stainless steel.

DynamicTalkB can be remotely controlled and diagnosed through the AHnet protocol (RS-422/RS-485 Full Duplex) and AHlink. DynamicTalkB shall be compatible with ERT-30 and ERT-60. The use of the Arthur Holm's ERT will enable the address configuration of all the units installed in a table by simply pressing a button. The DynamicTalkB is compatible with AHlink Android and iOS app allows access to the setup, diagnose and control menus.

Technical Specifications

Control

Up/Down Control	RS-422/RS-485 Full Duplex
	Capacitive button (standard version)

AHnet commands

Connectivity

USB port for firmware update

RS-422/RS-485 Full Duplex. AHnet protocol - RJ45 CAT6 FTP

Electrical

External power supply	100-240 Vac, 50/60Hz, 12Vdc
Power consumption	16W

Materials

Housing	Brushed stainless steel or black matt finish
---------	--

Mechanical

Cover plate	Ø 254 x 3 mm [10.00" x 0.12"]
Housing below the table	Ø 251 x 211 mm [9.88" x 8.31"]
Weight	8 Kg / 17.63Lbs

Finishes

- Underneath installation
- Painted

Warranty

- 2 years general warranty

Certifications

- CE
- CB
- IECEE
- RoHS
- EMC

Consultants, architects and engineers specifications

Professional motorized lift system that shall lift and retract boundary microphones. The cover plate shall be made of stainless steel. AHDTB shall be activated by a flush mounted control capacitive sensor or via AHnet protocol. The unit shall be compatible with a wireless app that allows its setup and control. AHDTB shall provide an addressable RS-422 / RS-485 Full Duplex for the setup, diagnose and control, and shall be compatible with ERT-30 and ERT 60.

AHDTB shall be able to run an auto-adjustment program to re-set the factory security ratio between its factory movement speed and its protection parameters adapting the unit to the way it has been installed. The monitor shall provide a USB port for firmware upgrades. The monitor shall be compatible with the AHlink wireless Android and iOS App for the setup, diagnosis and control.

ARTHUR HOLM

Albiral Display Solutions SL · Fàtima, 25 08512 Sant Hipòlit de Voltregà Barcelona, Spain · +34 938 502 376 · marketing@arthurholm.com · www.arthurholm.com
Arthur Holm is a registered brand of Albiral Display Solutions SL. Specifications subject to change without previous notice.

Make Your Meetings Count!

Connectivity Panel

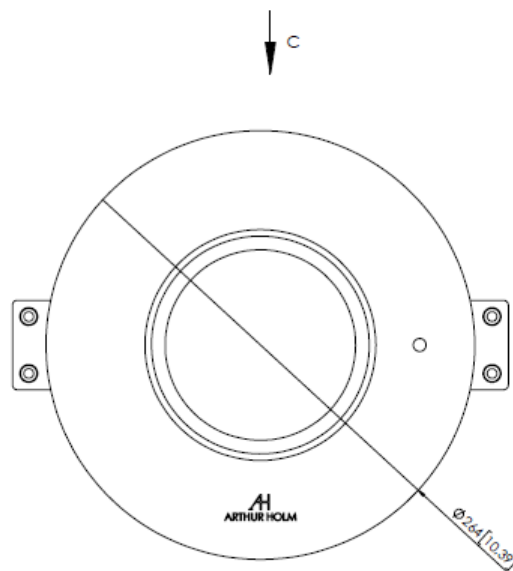
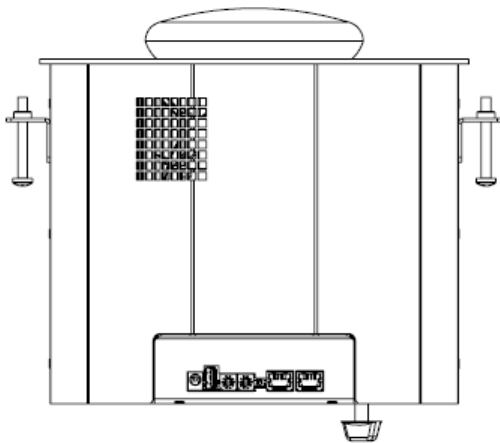
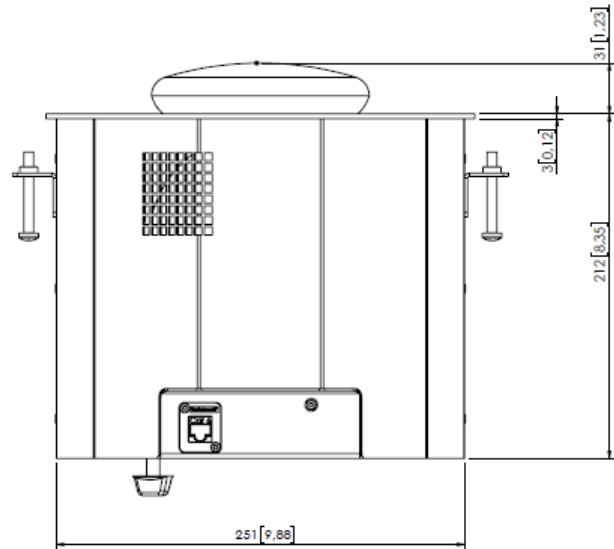
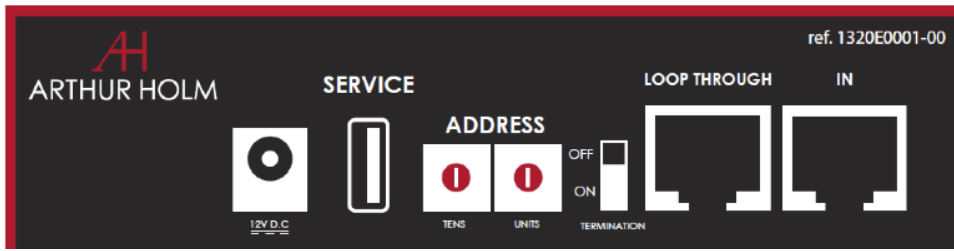

ARTHUR HOLM

Albiral Display Solutions SL · Fàtima, 25 08512 Sant Hipòlit de Voltregà Barcelona, Spain · +34 938 502 376 · marketing@arthurholm.com · www.arthurholm.com
 Arthur Holm is a registered brand of Albiral Display Solutions SL. Specifications subject to change without previous notice.

Make Your Meetings Count!

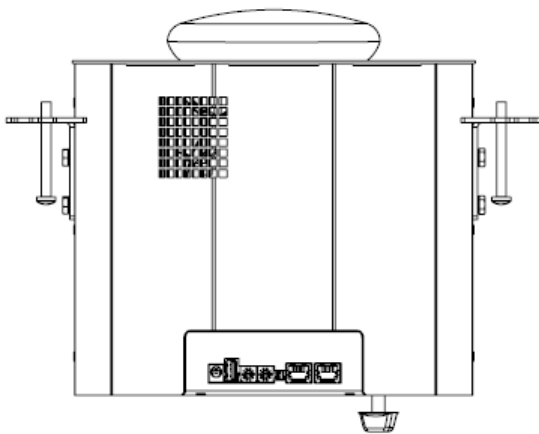
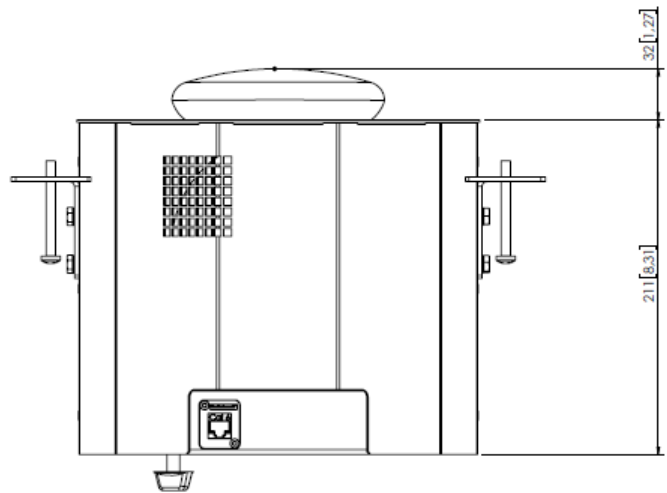

VIEW C
↻ 180.00°

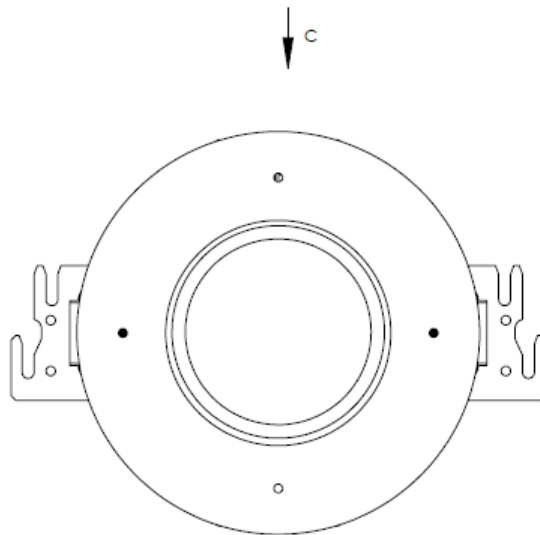

ARTHUR HOLM

Albiral Display Solutions SL · Fàtima, 25 08512 Sant Hipòlit de Voltregà Barcelona, Spain · +34 938 502 376 · marketing@arthurholm.com · www.arthurholm.com
Arthur Holm is a registered brand of Albiral Display Solutions SL. Specifications subject to change without previous notice.

Make Your Meetings Count!