

DynamicTalk UnderCover

Universal motorized lift system for gooseneck microphones with automated cover for veneering



Highlights

- Universal lift system for gooseneck XLR 3-pin microphones
- Patented motorized hatch for veneering
- Patented 360° LED lighting ring to indicate microphone status and protect the movement of the microphone
- PA and Conference working modes
- Auto Mechanical Movement Calibration (AH-AMMC)
- Compatible wireless connectivity for setup and control via AHlink

General

DynamicTalk UnderCover is a retractable system for gooseneck microphones which allows an easy veneering to provide a seamless integration in the furniture. It not only makes the microphone disappear within the desk surface but it also provides a pleasant light to indicate its status clearly indicating to the rest of the participants whose microphone is open. Thanks to its protective and patented lighting ring, the microphones can be safely stored and protected making meeting and conference spaces more flexible and versatile.

DynamicTalk UnderCover provides two different working modes: PA and Conference. When in PA mode, a push button placed on the stainless steel cover plate allows to activate or de-activate the microphone and the LED ring will indicate the status by changing color from red to green or vice versa. This microphone lifting system automatically silences the microphone when retracting whereas in conference mode the microphone remains active and can be controlled via GPI and GPO.

The cover plate is made of brushed stainless steel with optional integration of different interfaces and with the possibility to have different finishes. DynamicTalk UnderCover is available in 3 standard sizes: 400 mm, 500 mm, 600 mm (for short, medium and large microphones with XLR, 3-pin connector) and the it can be adjusted to fit the exact length of each microphone via AHnet and AHlink. DynamicTalk UnderCover shall be compatible with ERT-30 and ERT-60. The use of the Arthur Holm's ERT will enable the address configuration of all the units installed in a table by simply pressing a button. The DynamicTalk UnderCover is compatible with AHlink Android and iOS app allows access to the setup, diagnose and control menus.

Customized versions are also available for several types and sizes of conference microphones and conference brands.

Technical Specifications

Movement's Control

Up/Down Control	Button on cover plate (down movement)
	GPI/O contact close (compatible with external box with GPI remote control interface with 2 buttons)
	RS-422/RS-485 Full Duplex (RJ45 CAT 6 FTP)
Microphone Control	Button on cover plate
PA Mode	GPI/O contact closer
	RS-422/RS-485 Full Duplex (RJ45 CAT 6 FTP)
Free button	Button on cover plate
GPI/O	LEDs, up/down and button signal
AHlink	

Electrical

External power supply	100-240 Vac, 50/60Hz, 12Vdc
Power consumption	10W

Mechanical

Housing below the table	123.5 x 164.75 x 499 mm [4.86" x 6.49" x 19.65"]
Weight	7Kg / 15.43 Lbs
Maximum microphone length	400 mm [15.7"]

ARTHUR HOLM

Options

- Integrated USB passthrough on the cover plate
- 2 integrated USB passthrough on the cover plate
- USB power outlet on the cover plate
- Customization for audioconference brands

Certifications

- CE
- CB
- IECCE
- RoHS
- EMC

Warranty

- 2 years general warranty

Consultants, architects and engineers specifications

Professional retractable system for 3-pin XLR gooseneck microphones with a maximum length of 400mm especially designed to be veneered. The automated hatch shall be made of coated painted steel and shall be activated by an electric engine that drives it inside the table.

The system shall provide 3 operation buttons to open/close, mute/unmute and a free GPO. The system shall include a translucent plastic round ring to center the microphone during its rise and retract movement from a position hidden below the cover to a top position projected through the cover preventing the microphone from touching the cover plate, damaging or blocking when retracting. The LED ring shall have movement and provide a programmable red or green light and shall be 360° visible. The system shall be equipped with RS-422/RS-485 Full Duplex, RJ-45 and AHnet open protocol and shall allow individual remote control, setup and diagnosis of up to 30 units per line. The unit shall provide GPI (contact close to control the movements), GPO (contact close to detect button activation) and a USB for firmware upgrades. The unit shall provide a safety system that detects obstructions and shall cause the unit to stop with an audio indication. The unit shall provide and auto calibration mode to reset mechanical speeds and safety adjustments. The unit shall provide an automatic RS-422/RS-485 Full Duplex addressing system when used in combination with ERT-30 and ERT-60. The unit shall be compatible with a wireless app that allows to adjust the system to the exact microphone length and to change the working mode from PA to Conference.

Connectivity Panel

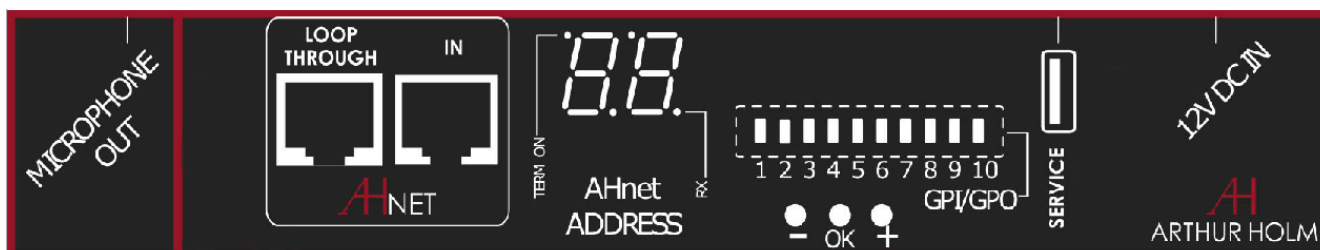

ARTHUR HOLM

Albiral Display Solutions SL · Fàtima, 25 08512 Sant Hipòlit de Voltregà Barcelona, Spain · +34 938 502 376 · marketing@arthurholm.com · www.arthurholm.com
 Arthur Holm is a registered brand of Albiral Display Solutions SL. Specifications subject to change without previous notice.

Make Your Meetings Count!

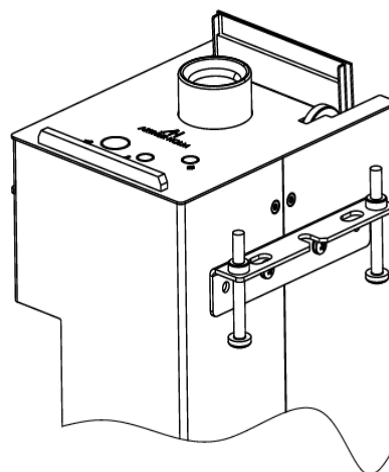
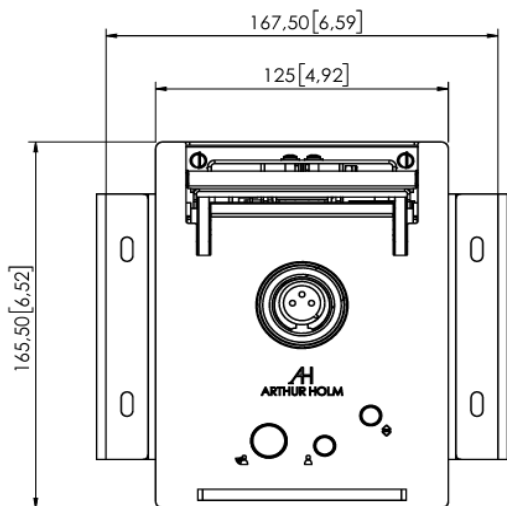
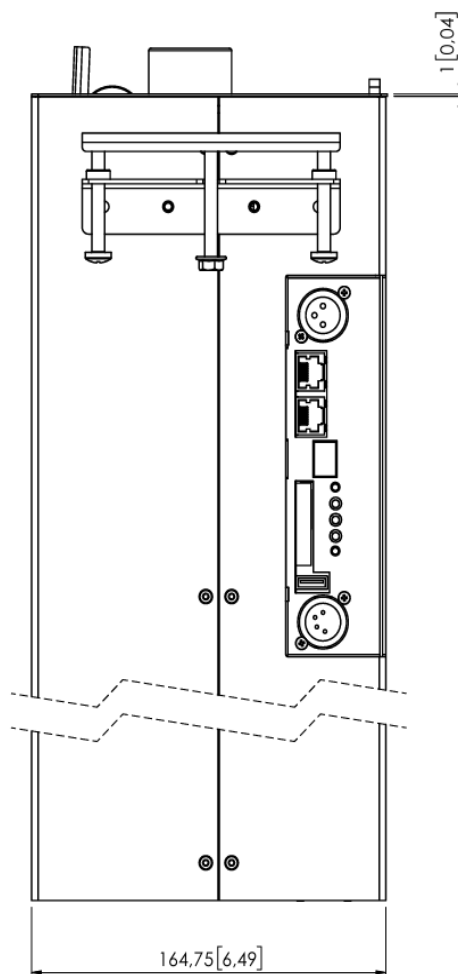
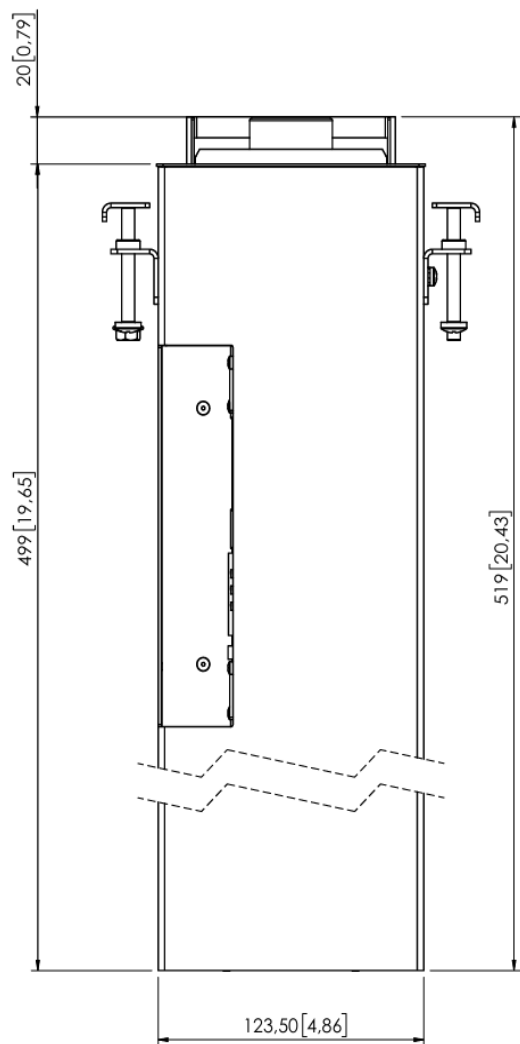

ARTHUR HOLM

Albiral Display Solutions SL · Fàtima, 25 08512 Sant Hipòlit de Voltregà Barcelona, Spain · +34 938 502 376 · marketing@arthurholm.com · www.arthurholm.com
 Arthur Holm is a registered brand of Albiral Display Solutions SL. Specifications subject to change without previous notice.

Make Your Meetings Count!