

AH1

Professional HDCP compliant aluminium manually foldable monitor



Highlights

- Professional manually foldable monitor
- Milled anodized aluminum housing
- Manually foldable from 0° to 80°
- Stepless viewing position
- Double-sided anti-reflective glass
- Auto-Stand-By
- Easy to install
- USB passthrough
- Maintenance free
- Energy saving design, low consumption video controller

ARTHUR HOLM

Albiral Display Solutions SL · Fàtima, 25 Sant Hipòlit de Voltregà 08512 Barcelona, Spain · +34 938 502 376 · marketing@arthurholm.com · www.arthurholm.com
Arthur Holm is a registered brand of Albiral Display Solutions SL. Specifications subject to change without previous notice.

MakeYourMeetingsCount

General

Arthur Holm AH1 manually foldable professional monitors are the perfect solution to create a flexible and versatile meeting environment when the space is limited. The monitor is fixed to the table surface through its black iron base, allowing the user to adjust the viewing angle of the monitor and hold the monitor in a firm viewing position.

The base hides the cable connection and guides the cables unseen away from the monitor when using the cable exit in the centre of the base or, if needed, the rear cable outlet.

The screen position can be easily adjusted from flat on the table (0°) to 80°. The monitor includes a USB passthrough from the side.

Technical Specifications

Display

Size	Full HD 21.5" TFT Active Matrix, widescreen. LED backlight
Resolution	1920 (h) x 1080 (v)
Brightness	500 cd/m2
Contrast ratio	1000:1
Pixel	0.24975 (h) x 0.24975 (v) mm
Viewing angle	89° / 89° (L/R) / 89° / 89° (U/D)
Viewing area	476.064 (h) x 267.786 (v)
Response time	Tr 12ms, Tf 10 ms
Temperature (operating/storage)	Operating 0°C ~ +40°C Storage -20°C ~ +60°C

Materials

Monitor housing	Milled aluminum with anodized finishing
Glass	Anti-reflective 2-side coating 3mm black edged glass
Base	Black aluminum anodized

Screen Control

IR	Screen Settings
----	-----------------

Connectivity

Input signal	HDMI - HDCP Compliant
HDMI	Female Cable 700mm
Power	Female Cable 700mm
USB-C	Pass Through cable 700mm
Touch Screen (only when there is Touch Screen)	Male USB-A Cable 700mm

Electrical

External power supply	100-240 Vac, 47/63Hz, 12Vdc
Power consumption	60W

Mechanical Dimensions

Monitor Dimensions	518 x 338.2 x 25 mm [20.39" x 13.32" x 0.98"]
Weight	20 Kg / 44.09 Lbs

Packaging Dimensions:

Weight	21.1 Kg / 46.8 Lbs
Box	700 x 560 x 225 mm aprox [27.55" x 22.04" x 8.85"]

Options

- Projected capacitive multi-touch screen

Certifications

- CE
- ICEE
- CB
- RoHS

Warranty

- 2 years general warranty

Consultants, architects and engineers specifications

The monitor shall provide a manually adjustable position from 0° to 80°. The monitor housing shall be made of anodized aluminum with an anti-reflective 2-side coating 3 mm black edged glass. The monitor shall provide a black iron base with hidden cables and no visible screws.

The 21.5" Full HD monitor shall have a brightness of 500 cd/m2 and a contrast ratio of 1000:1. The monitor shall provide 1 HDMI HDCP inputs by a licensed HDCP manufacturer from the side.

ARTHUR HOLM

Albiral Display Solutions SL · Fàtima, 25 Sant Hipòlit de Voltregà 08512 Barcelona, Spain · +34 938 502 376 · marketing@arthurholm.com · www.arthurholm.com
Arthur Holm is a registered brand of Albiral Display Solutions SL. Specifications subject to change without previous notice.

MakeYourMeetingsCount

Open 80°

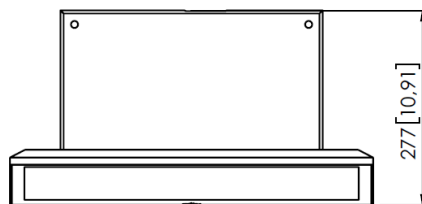
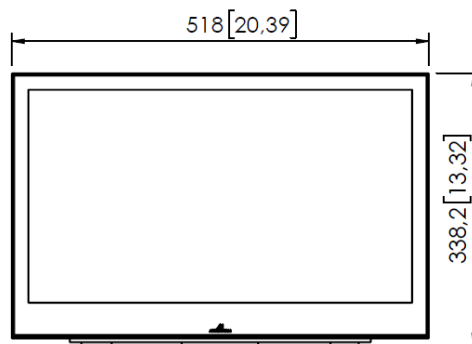
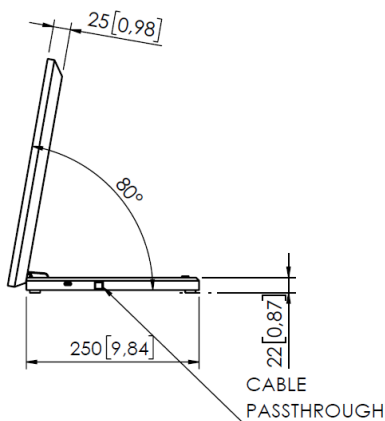
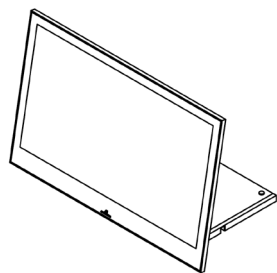

Closed 0°

