

AH2

Professional HDCP compliant aluminum manually foldable monitor

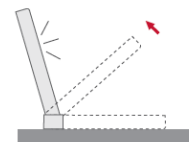

Highlights

- Professional manually foldable monitor
- Milled aluminum with black anodized finishing
- Manually foldable from 0° to 110°
- Stepless viewing position
- Anti-reflective glass
- Auto-Stand-By / Auto-ON/OFF position based
- Easy to install
- Limited space is required under the table surface
- Maintenance free
- Energy saving design, low consumption video controller



General

The AH2 is a premium manually foldable monitor, crafted from black anodized aluminum and designed for seamless integration into meeting and conference tables. Its elegant, low-profile design allows the screen to be folded completely flat above the table, with the display facing down for maximum protection when not in use. When required, the monitor opens manually up to 110°, providing optimal viewing comfort.

Thanks to its minimal installation depth, the AH2 is particularly suitable for open tables, maximizing available workspace while maintaining a clean and uncluttered appearance. The monitor is mounted directly onto the table surface and can be easily folded away, restoring unobstructed sightlines between participants

and across the room, fostering natural communication and collaboration.

The compact installation footprint also ensures ample cable-free working space, allowing users to comfortably combine digital content on the screen with documents and other materials on the desk.

For enhanced durability and viewing quality, the display is protected by a 2 mm anti-glare glass and features an HDMI input.

Technical Specifications

Display

Size	Full HD 21.5" TFT Active Matrix, widescreen format. LED backlight.
Resolution	1920 (h) x 1080 (v)
Brightness	500 cd/m2
Contrast ratio	1000:1
Pixel	0.24795 (h) x 0.24795 (v) mm
Viewing angle	89°/89° (u/d) / 89°/89° (l/r)
Viewing area	476.064 (h) x 267.786 (v) mm
Response time	Tr 12ms, Tf 10ms
Temperature (operating/storage)	Operating 0°C ~+40°C Storage -20°C ~+60°C

Materials

Monitor housing	Milled aluminum with black anodized finishing
Glass	Anti-reflective 2mm black edged glass

Connectivity

Input signal	HDMI – HDCP Compliant
Cable HDMI	Female Cable 700mm
Cable Power	Female Cable 700mm
Cable Touch Screen (only when there is Touch Screen)	Male USB-A Cable 700mm

Electrical

External power supply	100-240 Vac, 50/60Hz, 12Vdc
Power consumption	55W

Mechanical

Monitor dimensions	518 x 369.23 x 23 mm [20.39" x 14.54" x 0.91"]
Weight	3.1 Kg / 6.83 Lbs aprox.

Shipping Dimensions

Monitor dimensions	635 x 530 x 225 mm [25.00" x 20.87" x 8.86"]
Weight	4.1Kg / 9.04 Lbs aprox

Control Panel



Options

- Projected capacitive multi-touch screen

Certifications

- CE
- IECCE
- CB
- RoHS

Warranty

- 2 years general warranty

ARTHUR HOLM

Albiral Display Solutions SL · Fàtima, 25 · 08512 Sant Hipòlit de Voltregà · Barcelona, Spain · +34 938 502 376 · marketing@arthurholm.com · www.arthurholm.com

Arthur Holm is a registered brand of Albiral Display Solutions SL. Specifications subject to change without previous notice.

MakeYourMeetingsCount

Consultants, architects and engineers specifications

The monitor shall provide a manually adjustable position from 0° to 110°. The monitor housing shall be made of anodized aluminum with an anti-reflective 2 mm black edged glass. The monitor shall have one milled aluminum mounting support, allowing the user to adjust the viewing area of the monitor and holding the monitor in a firm working position.

All connectors shall be placed under the table and cables shall be unseen through the base to the monitor. The 21.5" Full HD monitor shall have a brightness of 500cd/m2 and a contrast ratio of 1000:1. The monitor shall provide 1 HDMI HDCP input by a licensed HDCP manufacturer.

General Dimensions

OPENED

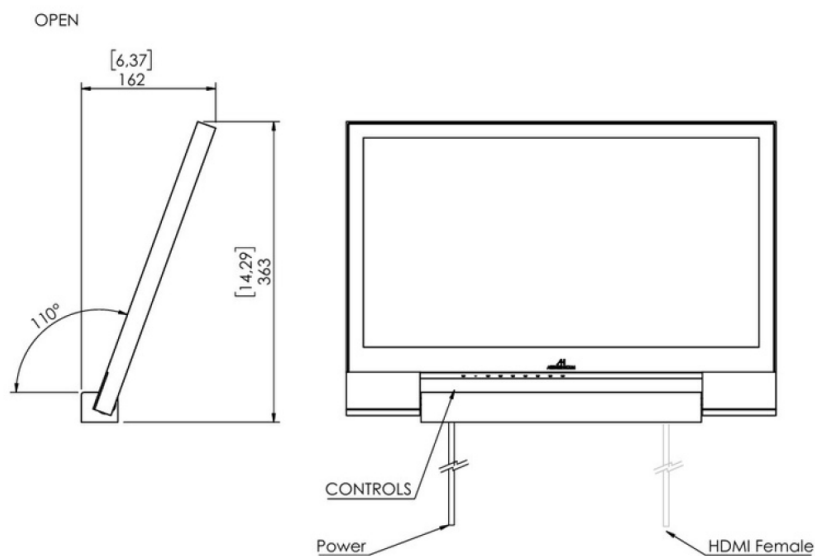

CLOSED

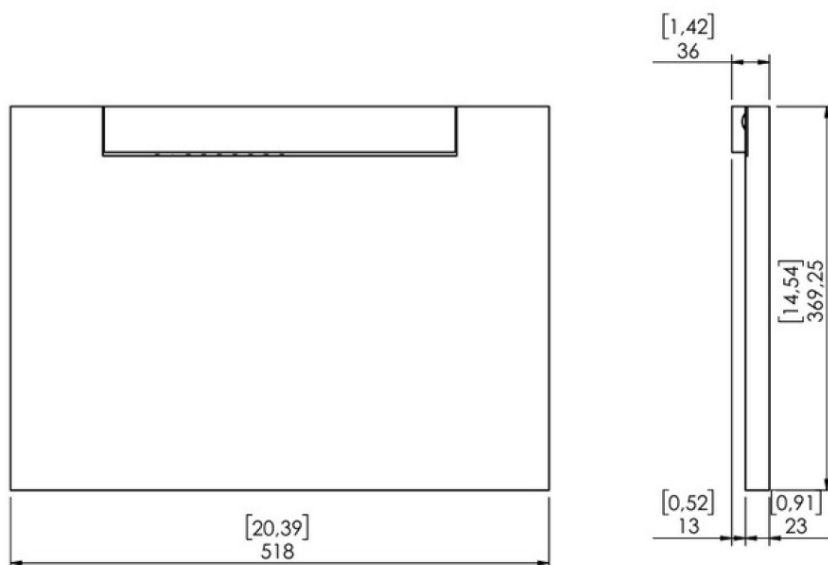

ARTHUR HOLM

Albiral Display Solutions SL · Fàtima, 25 · 08512 Sant Hipòlit de Voltregà · Barcelona, Spain · +34 938 502 376 · marketing@arthurholm.com · www.arthurholm.com

Arthur Holm is a registered brand of Albiral Display Solutions SL. Specifications subject to change without previous notice.

MakeYourMeetingsCount